

SANITARY SEWER

TABLE OF CONTENTS

CHAPTER 95 - SANITARY SEWER SYSTEM.....	783
CHAPTER 96 - BUILDING SEWERS AND CONNECTIONS	791
CHAPTER 97 - USE OF PUBLIC SEWERS	799
CHAPTER 98 - ON-SITE WASTEWATER SYSTEMS	807
CHAPTER 99 - SEWER SERVICE CHARGES	813

CHAPTER 95

SANITARY SEWER SYSTEM

95.01 Purpose

95.02 Definitions

95.03 Superintendent

95.04 Prohibited Acts

95.05 Sewer Connection Required

95.06 Service Outside the City

95.07 Right of Entry

95.08 Use of Easements

95.09 Special Penalties

95.10 Abandoned Sewer Lines

95.01 PURPOSE. The purpose of the chapters of this Code of Ordinances pertaining to Sanitary Sewers is to establish rules and regulations governing the treatment and disposal of sanitary sewage within the City in order to protect the public health, safety, and welfare.

95.02 DEFINITIONS. For use in these chapters, unless the context specifically indicates otherwise, the following terms are defined:

1. "B.O.D." (denoting Biochemical Oxygen Demand) means the quantity of oxygen utilized in the biochemical oxidation of organic matter under standard laboratory procedure in five days at 20°C, expressed in milligrams per liter or parts per million.
2. "Building drain" means that part of the lowest horizontal piping of a building drainage system which receives the discharge from soil, waste, and other drainage pipes inside the walls of the building and conveys it to the building sewer, beginning five feet (one and one-half meters) outside the inner face of the building wall.
3. "Building sewer" means that part of the horizontal piping from the building wall to its connection with the main sewer or the primary treatment portion of an on-site wastewater treatment and disposal system conveying the drainage of one building site.
4. "Combined sewer" means a sewer receiving both surface run-off and sewage.
5. "Customer" means any person responsible for the production of domestic, commercial, or industrial waste that is directly or indirectly discharged into the public sewer system.
6. "Garbage" means solid wastes from the domestic and commercial preparation, cooking and dispensing of food, and from the handling, storage, and sale of produce.
7. "Industrial wastes" means the liquid wastes from industrial manufacturing processes, trade, or business as distinct from sanitary sewage.
8. "Inspector" means the person duly authorized by the Council to inspect and approve the installation of building sewers and their connections to the public sewer system; and to inspect such sewage as may be discharged therefrom.
9. "Natural outlet" means any outlet into a watercourse, pond, ditch, lake, or other body of surface or groundwater.
10. "On-site wastewater treatment and disposal system" means all equipment and devices necessary for proper conduction, collection, storage, treatment, and disposal of wastewater from four or fewer dwelling units or other facilities serving the equivalent of 15 persons (1,500 gpd) or less.

11. “pH” means the logarithm of the reciprocal of the weight of hydrogen ions in grams per liter of solution.
12. “Public sewer” means a sewer in which all owners of abutting properties have equal rights, and is controlled by public authority.
13. “Sanitary sewage” means sewage discharging from the sanitary conveniences of dwellings (including apartment houses and hotels), office buildings, factories, or institutions, and free from storm, surface water, and industrial waste.
14. “Sanitary sewer” means a sewer that carries sewage and to which storm, surface, and ground waters are not intentionally admitted.
15. “Sewage” means a combination of the water-carried wastes from residences, business buildings, institutions, and industrial establishments, together with such ground, surface, and stormwaters as may be present.
16. “Sewage treatment plant” means any arrangement of devices and structures used for treating sewage.
17. “Sewage works” or “sewage system” means all facilities for collecting, pumping, treating, and disposing of sewage.
18. “Sewer” means a pipe or conduit for carrying sewage.
19. “Sewer service charges” means any and all charges, rates or fees levied against and payable by customers, as consideration for the servicing of said customers by said sewer system.
20. “Slug” means any discharge of water, sewage, or industrial waste that in concentration of any given constituent or in quantity of flow exceeds for any period of duration longer than 15 minutes more than five times the average 24-hour concentration or flows during normal operation.
21. “Storm drain” or “storm sewer” means a sewer that carries storm and surface waters and drainage but excludes sewage and industrial wastes, other than unpolluted cooling water.
22. “Superintendent” means the Superintendent of sewage works or of water pollution control of the City or any authorized deputy, agent, or representative.
23. “Suspended solids” means solids that either float on the surface of, or are in suspension in water, sewage, or other liquids, and that are removable by laboratory filtering.
24. “Watercourse” means a channel in which a flow of water occurs, either continuously or intermittently.

95.03 SUPERINTENDENT. The Superintendent shall exercise the following powers and duties:

(Code of Iowa, Sec. 372.13[4])

1. Operation and Maintenance. Operate and maintain the City sewage system.
2. Inspection and Tests. Conduct necessary inspections and tests to assure compliance with the provisions of these Sanitary Sewer chapters.
3. Records. Maintain a complete and accurate record of all sewers, sewage connections, and manholes constructed showing the location and grades thereof.

95.04 PROHIBITED ACTS. No person shall do, or allow, any of the following:

1. Damage Sewer System. Maliciously, willfully, or negligently break, damage, destroy, uncover, deface, or tamper with any structure, appurtenance, or equipment that is a part of the sewer system.

(Code of Iowa, Sec. 716.1)

2. Surface Run-Off or Groundwater. Connect a roof downspout, sump pump, exterior foundation drain, areaway drain, or other source of surface run-off or groundwater to a building sewer or building drain that is connected directly or indirectly to a public sanitary sewer.

3. Manholes. Open or enter any manhole of the sewersystem, except by authority of the Superintendent.

4. Objectionable Wastes. Place or deposit in any unsanitary manner on public or private property within the City, or in any area under the jurisdiction of the City, any human or animal excrement, garbage, or other objectionable waste.

5. Septic Tanks. Construct or maintain any privy, privy vault, septic tank, cesspool, or other facility intended or used for the disposal of sewage except as provided in these chapters.

(Code of Iowa, Sec. 364.12[3ff])

6. Untreated Discharge. Discharge to any natural outlet within the City, or in any area under its jurisdiction, any sanitary sewage, industrial wastes, or other polluted waters, except where suitable treatment has been provided in accordance with subsequent provisions of these chapters.

(Code of Iowa, Sec. 364.12[3ff])

95.05 SEWER CONNECTION REQUIRED. The owners of any houses, buildings, or properties used for human occupancy, employment, recreation or other purposes, situated within the City and abutting on any street, alley or right-of-way in which there is now located, or may in the future be located, a public sanitary or combined sewer, are hereby required to install, at such owner's expense, suitable toilet facilities therein and a building sewer connecting such facilities directly with the proper public sewer, and to maintain the same all in accordance with the provisions of these Sanitary Sewer chapters, such compliance to be completed within 60 days after date of official notice from the City to do so provided that said public sewer is located within 100 feet of the property line of such owner and is of such design as to receive and convey by gravity such sewage as may be conveyed to it. Billing for sanitary sewer service will begin the date of official notice to connect to the public sewer.

(Code of Iowa, Sec. 364.12[3ff])

(567 IAC 69.1[3])

95.06 SERVICE OUTSIDE THE CITY. The owners of property outside the corporate limits of the City so situated that it may be served by the City sewer system may apply to the Council for permission to connect to the public sewer upon the terms and conditions stipulated by resolution of the Council.

(Code of Iowa, Sec. 364.4[2 and 3])

95.07 RIGHT OF ENTRY. The Superintendent and other duly authorized employees of the City bearing proper credentials and identification shall be permitted to enter all properties for the purposes of inspection, observation, measurement, sampling, and testing in accordance with the provisions of these Sanitary Sewer chapters. The Superintendent or representatives shall

have no authority to inquire into any processes including metallurgical, chemical, oil, refining, ceramic, paper, or other industries beyond that point having a direct bearing on the kind and source of discharge to the sewers or waterways or facilities for waste treatment.

95.08 USE OF EASEMENTS. The Superintendent and other duly authorized employees of the City bearing proper credentials and identification shall be permitted to enter all private properties through which the City holds a duly negotiated easement for the purposes of, but not limited to, inspection, observation, measurement, sampling, repair, and maintenance of any portion of the sewage works lying within said easement. All entry and subsequent work, if any, on said easement, shall be done in full accordance with the terms of the duly negotiated easement pertaining to the private property involved.

95.09 SPECIAL PENALTIES. The following special penalty provisions shall apply to violations of these Sanitary Sewer chapters:

1. Notice of Violation. Any person found to be violating any provision of these chapters except Subsections 1, 3, and 4 of Section 95.04, shall be served by the City with written notice stating the nature of the violation and providing a reasonable time limit for the satisfactory correction thereof. The offender shall, within the period of time stated in such notice, permanently cease all violations.
2. Continuing Violations. Any person who shall continue any violation beyond the time limit provided for in Subsection 1 hereof shall be in violation of this Code of Ordinances. Each day in which any such violation shall continue shall be deemed a separate offense.
3. Liability Imposed. Any person violating any of the provisions of these chapters shall become liable to the City for any expense, loss, or damage occasioned the City by reason of such violation.

95.10 ABANDONED SEWER LINES. When an existing sanitary sewer service is abandoned or a service is renewed with a new connection in the main, all abandoned connections with the mains shall be capped off and made absolutely watertight.

[The next page is 791]

CHAPTER 96

BUILDING SEWERS AND CONNECTIONS

96.01 Permit	96.06 Interceptors Required
96.02 Permit Fee	96.07 Sewer Tap
96.03 Plumber Required	96.08 Inspection Required
96.04 Excavations	96.09 Property Owner's Responsibility
96.05 Connection Requirements	96.10 Abatement of Violations

96.01 PERMIT. No unauthorized person shall uncover, make any connection with or opening into, use, alter, or disturb any public sewer or appurtenance thereof without first obtaining a written permit from the City. The application for the permit shall set forth the following information:

1. The location and description of the property to be connected with the sewer system.
2. The purpose for which the sewer is to be used.
3. Plans, specifications, or other information considered pertinent.

The permit shall require the owner to complete construction and connection of the building sewer to the public sewer within 60 days after the issuance of the permit, except that when a property owner makes sufficient showing that due to conditions beyond the owner's control or peculiar hardship, such time period is inequitable or unfair, an extension of time within which to comply with the provisions herein may be granted. Any sewer connection permit may be revoked at any time for a violation of these chapters.

96.02 PERMIT FEE. The person who makes the application shall pay a fee in the amount of \$25.00 for residential and commercial and \$75.00 for industrial to the Clerk to cover the cost of issuing the permit and supervising, regulating, and inspecting the work.

96.03 PLUMBER REQUIRED. All installations of building sewers and connections to the public sewer shall be made by a State-licensed plumber.

96.04 EXCAVATIONS. All trench work, excavation, and backfilling required for the installation of a building sewer shall be performed in accordance with the provisions of the *State Plumbing Code* and the provisions of Chapter 135 of this Code of Ordinances.

96.05 CONNECTION REQUIREMENTS. Any connection with a public sanitary sewer must be made under the direct supervision of the Superintendent and in accordance with the following:

1. **Old Building Sewers.** Old building sewers may be used in connection with new buildings only when they are found, on examination and test conducted by the owner and observed by the Superintendent, to meet all requirements of this chapter.
2. **Separate Building Sewers.** A separate and independent building sewer shall be provided for every occupied building; except where one building stands at the rear of another on an interior lot and no private sewer is available or can be constructed to the rear building through an adjoining alley, court, yard, or driveway. In such cases the

building sewer from the front building may be extended to the rear building and the whole considered as one building sewer.

3. Installation. The installation and connection of the building sewer to the public sewer shall conform to the requirements of the *State Plumbing Code* and applicable rules and regulations of the City. All such connections shall be made gastight and watertight. Any deviation from the prescribed procedures and materials must be approved by the Superintendent before installation.

4. Water Lines. When possible, building sewers should be laid at least 10 feet horizontally from a water service. The horizontal separation may be less, provided the water service line is located at one side and at least 12 inches above the top of the building sewer.

5. Size. Building sewers shall be sized for the peak expected sewage flow from the building with a minimum building sewer size of four inches.

6. Alignment and Grade. All building sewers shall be laid to a straight line to meet the following:

- A. Recommended grade at one-fourth inch per foot.
- B. Minimum grade of one-eighth inch per foot.
- C. Minimum velocity of two feet per second with the sewer half full.
- D. Any deviation in alignment or grade shall be made only with the written approval of the Superintendent and shall be made only with approved fittings.

7. Depth. Whenever possible, the building sewer shall be brought to the building at an elevation below the basement floor. The depth of cover above the sewer shall be sufficient to afford protection from frost.

8. Sewage Lifts. In all buildings in which any building drain is too low to permit gravity flow to the public sewer, sanitary sewage carried by such drain shall be lifted by approved artificial means and discharged to the building sewer.

9. Pipe Specifications. Building sewer pipe shall be free from flaws, splits, or breaks. Materials shall be as specified in the *State Plumbing Code* except that the building sewer pipe, from the property line to the public sewer, shall comply with the current edition of one of the following:

- A. Clay sewer pipe – A.S.T.M. C-700 (extra strength).
- B. Extra heavy cast iron soil pipe – A.S.T.M. A-74.
- C. Ductile iron water pipe – A.W.W.A. C-151.
- D. P.V.C. – SDR26 – A.S.T.M. D-3034.

10. Bearing Walls. No building sewer shall be laid parallel to or within three feet of any bearing wall that might thereby be weakened.

11. Jointing. Fittings, type of joint and jointing material shall be compatible with the type of pipe used, subject to the approval of the Superintendent. Solvent-welded joints are not permitted.

12. Unstable Soil. No sewer connection shall be laid so that it is exposed when crossing any watercourse. Where an old watercourse must of necessity be crossed or where there is any danger of undermining or settlement, cast iron soil pipe or vitrified

clay sewer pipe thoroughly encased in concrete shall be required for such crossings. Such encasement shall extend at least six inches on all sides of the pipe. The cast iron pipe or encased clay pipe shall rest on firm, solid material at either end.

13. Preparation of Basement or Crawl Space. No connection for any residence, business or other structure with any sanitary sewer shall be made unless the basement floor is poured, or in the case of a building with a slab or crawl space, unless the ground floor is installed with the area adjacent to the foundation of such building cleared of debris and backfilled. The backfill shall be well compacted and graded so that the drainage is away from the foundation. Prior to the time the basement floor is poured, or the first floor is installed in buildings without basements, the sewer shall be plugged and the plug shall be sealed by the Superintendent. Any accumulation of water in any excavation or basement during construction and prior to connection to the sanitary sewer shall be removed by means other than draining into the sanitary sewer.

96.06 INTERCEPTORS REQUIRED. Grease, oil, sludge, and sand interceptors shall be provided by gas and service stations, convenience stores, car washes, garages, and other facilities when, in the opinion of the Superintendent, they are necessary for the proper handling of such wastes that contain grease in excessive amounts or any flammable waste, sand, or other harmful ingredients. Such interceptors shall not be required for private living quarters or dwelling units. When required, such interceptors shall be installed in accordance with the following:

1. Design and Location. All interceptors shall be of a type and capacity as specified in the *State Plumbing Code*, to be approved by the Superintendent, and shall be located so as to be readily and easily accessible for cleaning and inspection.
2. Construction Standards. The interceptors shall be constructed of impervious material capable of withstanding abrupt and extreme changes in temperature. They shall be of substantial construction, watertight and equipped with easily removable covers that shall be gastight and watertight.
3. Maintenance. All such interceptors shall be maintained by the owner at the owner's expense and shall be kept in continuously efficient operations at all times.

96.07 SEWER TAP. Connection of the building sewer into the public sewer shall be made at the "Y" branch, if such branch is available at a suitable location. If no properly located "Y" branch is available, a saddle "Y" shall be installed at the location specified by the Superintendent. The public sewer shall be tapped with a tapping machine and a saddle appropriate to the type of public sewer shall be glued or attached with a gasket and stainless steel clamps to the sewer. At no time shall a building sewer be constructed so as to enter a manhole unless special written permission is received from the Superintendent and in accordance with the Superintendent's direction if such connection is approved.

96.08 INSPECTION REQUIRED. All connections with the sanitary sewer system before being covered shall be inspected and approved, in writing, by the Superintendent. As soon as all pipe work from the public sewer to inside the building has been completed, and before any backfilling is done, the Superintendent shall be notified and the Superintendent shall inspect and test the work as to workmanship and material; no sewer pipe laid underground shall be covered or trenches filled until after the sewer has been so inspected and approved. If the Superintendent refuses to approve the work, the plumber or owner must proceed immediately to correct the work.

96.09 PROPERTY OWNER'S RESPONSIBILITY. All costs and expenses incident to the installation, connection, and maintenance of the building sewer, from main, including the tap to the building served, shall be borne by the owner. The owner shall indemnify the City from any loss or damage that may directly or indirectly be occasioned by the installation of the building sewer.

96.10 ABATEMENT OF VIOLATIONS. Construction or maintenance of building sewer lines, whether located upon the private property of any owner or in the public right-of-way, which construction or maintenance is in violation of any of the requirements of this chapter, shall be corrected, at the owner's expense, within 30 days after date of official notice from the Council of such violation. If not made within such time, the Council shall, in addition to the other penalties herein provided, have the right to finish and correct the work and assess the cost thereof to the property owner. Such assessment shall be collected with and in the same manner as general property taxes.

(Code of Iowa, Sec. 364.12[3])

[The next page is 799]

CHAPTER 97

USE OF PUBLIC SEWERS

97.01 Stormwater

97.02 Surface Waters Exception

97.03 Prohibited Discharges

97.04 Restricted Discharges

97.05 Restricted Discharges; Powers of Superintendent

97.06 Special Facilities

97.07 Control Manholes

97.08 Testing of Wastes

97.01 STORMWATER. No person shall discharge or cause to be discharged any stormwater, surface water, groundwater, roof run-off, sub-surface drainage, uncontaminated cooling water, or unpolluted industrial process waters to any sanitary sewer. Stormwater and all other unpolluted drainage shall be discharged to such sewers that are specifically designated as combined sewers or storm sewers or to a natural outlet approved by the Superintendent. Industrial cooling water or unpolluted process waters may be discharged on approval of the Superintendent, to a storm sewer, combined sewer, or natural outlet.

97.02 SURFACE WATERS EXCEPTION. Special permits for discharging surface waters to a public sanitary sewer may be issued by the Council upon recommendation of the Superintendent where such discharge is deemed necessary or advisable for purposes of flushing, but any permit so issued shall be subject to revocation at any time when deemed to be in the best interests of the sewer system.

97.03 PROHIBITED DISCHARGES. No person shall discharge or cause to be discharged any of the following described waters or wastes to any public sewers:

1. Flammable or Explosive Material. Any gasoline, benzene, naphtha, fuel oil, or other flammable or explosive liquid, solid, or gas.
2. Toxic or Poisonous Materials. Any waters or wastes containing toxic or poisonous solids, liquids, or gases in sufficient quantity, either singly or by interaction with other wastes, to injure or interfere with any sewage treatment process, constitute a hazard to humans or animals, create a public nuisance, or create any hazard in the receiving waters of the sewage treatment plant, including but not limited to cyanides (CN) in excess of two milligrams per liter as CN in the wastes as discharged to the public sewer.
3. Corrosive Wastes. Any waters or wastes having a pH lower than 5.5 or having any other corrosive property capable of causing damage or hazard to structures, equipment, and personnel of the sewage works.
4. Solid or Viscous Substances. Solid or viscous substances in quantities or of such size capable of causing obstruction to the flow in sewers, or other interference with the proper operation of the sewage works such as, but not limited to, ashes, cinders, sand, mud, straw, shavings, metal, glass, rags, feathers, tar, plastics, wood, unground garbage, whole blood, paunch manure, hair and fleshings, entrails and paper dishes, cups, milk containers, etc., either whole or ground by garbage grinders.

5. Excessive B.O.D., Solids or Flow.
 - A. Any waters or wastes:
 - (1) Having a five-day biochemical oxygen demand greater than 300 parts per million by weight; or
 - (2) Containing more than 350 parts per million by weight of suspended solids; or
 - (3) Having an average daily flow greater than two percent of the average sewage flow of the City, shall be subject to the review of the Superintendent.
 - B. Where necessary in the opinion of the Superintendent, the owner shall provide, at the owner's expense, such preliminary treatment as may be necessary to:
 - (1) Reduce the biochemical oxygen demand to 300 parts per million by weight; or
 - (2) Reduce the suspended solids to 350 parts per million by weight; or
 - (3) Control the quantities and rates of discharge of such waters or wastes.
 - C. Plans, specifications, and any other pertinent information relating to proposed preliminary treatment facilities shall be submitted for the approval of the Superintendent, and no construction of such facilities shall be commenced until said approvals are obtained in writing.

97.04 RESTRICTED DISCHARGES. No person shall discharge or cause to be discharged the following described substances, materials, waters, or wastes if it appears likely in the opinion of the Superintendent that such wastes can harm either the sewers, sewage treatment process, or equipment, have an adverse effect on the receiving stream or can otherwise endanger life, limb, public property, or constitute a nuisance. In forming an opinion as to the acceptability of these wastes, the Superintendent will give consideration to such factors as the quantities of subject wastes in relation to flows and velocities in the sewers, materials of construction of the sewers, nature of the sewage treatment process, capacity of the sewage treatment plant, degree of treatability of wastes in the sewage treatment plant, and other pertinent factors. The substances restricted are:

1. High Temperature. Any liquid or vapor having a temperature higher than 150°F (65°C).
2. Fat, Oil, Grease. Any water or waste containing fats, wax, grease, or oils, whether emulsified or not, in excess of 100 milligrams per liter or 600 milligrams per liter of dispersed or other soluble matter.
3. Viscous Substances. Water or wastes containing substances that may solidify or become viscous at temperatures between 32°F and 150°F (0°C to 65°C).
4. Garbage. Any garbage that has not been properly shredded, that is, to such a degree that all particles will be carried freely under the flow conditions normally prevailing in public sewers, with no particle greater than one-half inch in any dimension.

5. Acids. Any waters or wastes containing strong acid iron pickling wastes, or concentrated plating solution, whether neutralized or not.
6. Toxic or Objectionable Wastes. Any waters or wastes containing iron, chromium, copper, zinc, and similar objectionable or toxic substances; or wastes exerting an excessive chlorine requirement, to such degree that any such material received in the composite sewage at the sewage treatment works exceeds the limits established by the Superintendent for such materials.
7. Odor or Taste. Any waters or wastes containing phenols or other taste or odor producing substances, in such concentrations exceeding limits that may be established by the Superintendent as necessary, after treatment of the composite sewage, to meet the requirements of State, federal, or other public agencies of jurisdiction for such discharge to the receiving waters.
8. Radioactive Wastes. Any radioactive wastes or isotopes of such half-life or concentration as may exceed limits established by the Superintendent in compliance with applicable State or federal regulations.
9. Excess Alkalinity. Any waters or wastes having a pH in excess of 9.5.
10. Unusual Wastes. Materials that exert or cause:
 - A. Unusual concentrations of inert suspended solids (such as, but not limited to, Fullers earth, lime slurries, and lime residues) or of dissolved solids (such as, but not limited to, sodium chloride and sodium sulfate).
 - B. Excessive discoloration (such as, but not limited to, dye wastes and vegetable tanning solutions).
 - C. Unusual B.O.D., chemical oxygen demand, or chlorine requirements in such quantities as to constitute a significant load on the sewage treatment works.
 - D. Unusual volume of flow or concentration of wastes constituting "slugs" as defined herein.
11. Noxious or Malodorous Gases. Any noxious or malodorous gas or other substance that, either singly or by interaction with other wastes, is capable of creating a public nuisance or hazard to life or of preventing entry into sewers for their maintenance and repair.
12. Damaging Substances. Any waters, wastes, materials, or substances that react with water or wastes in the sewer system to release noxious gases, develop color of undesirable intensity, form suspended solids in objectionable concentration, or create any other condition deleterious to structures and treatment processes.
13. Untreatable Wastes. Waters or wastes containing substances that are not amenable to treatment or reduction by the sewage treatment processes employed, or are amenable to treatment only to such degree that the sewage treatment plant effluent cannot meet the requirements of other agencies having jurisdiction over discharge to the receiving waters.

97.05 RESTRICTED DISCHARGES; POWERS OF SUPERINTENDENT. If any waters or wastes are discharged or are proposed to be discharged to the public sewers, which waters contain the substances or possess the characteristics enumerated in Section 97.04 and which in the judgment of the Superintendent may have a deleterious effect upon the sewage

works, processes, equipment, or receiving waters, or which otherwise create a hazard to life or constitute a public nuisance, the Superintendent may:

1. Rejection. Reject the wastes by requiring disconnection from the public sewage system;
2. Pretreatment. Require pretreatment to an acceptable condition for discharge to the public sewers;
3. Controls Imposed. Require control over the quantities and rates of discharge; or
4. Special Charges. Require payment to cover the added cost of handling and treating the wastes not covered by existing taxes or sewer charges under the provisions of Chapter 99.

97.06 SPECIAL FACILITIES. If the Superintendent permits the pretreatment or equalization of waste flows, the design and installation of the plants and equipment shall be subject to the review and approval of the Superintendent and subject to the requirements of all applicable codes, ordinances, and laws. Where preliminary treatment or flow-equalizing facilities are provided for any waters or wastes, they shall be maintained continuously in satisfactory and effective operation by the owner at the owner's expense.

97.07 CONTROL MANHOLES. When required by the Superintendent, the owner of any property serviced by a building sewer carrying industrial wastes shall install a suitable control manhole together with such necessary meters and other appurtenances in the building sewer to facilitate observation, sampling, and measurement of the wastes. Such manhole, when required, shall be accessibly and safely located, and shall be constructed in accordance with plans approved by the Superintendent. The manhole shall be installed by the owner at the owner's expense, and shall be maintained by the owner so as to be safe and accessible at all times.

97.08 TESTING OF WASTES. All measurements, tests, and analyses of the characteristics of waters and wastes to which reference is made in this chapter shall be determined in accordance with the latest edition of *Standard Methods for the Examination of Water and Wastewater*, published by the American Public Health Association, and shall be determined at the control manhole provided, or upon suitable samples taken at said control manhole. In the event that no special manhole has been required, the control manhole shall be considered to be the nearest downstream manhole in the public sewer to the point at which the building sewer is connected. Sampling shall be carried out by customarily accepted methods to reflect the effect of constituents upon the sewage works and to determine the existence of hazards to life, limb, and property. (The particular analyses involved will determine whether a 24-hour composite of all outfalls of a premises is appropriate or whether a grab sample or samples should be taken. Normally, but not always, B.O.D. and suspended solids analyses are obtained from 24-hour composites of all outfalls whereas pH's are determined from periodic grab samples.)

[The next page is 807]

CHAPTER 98

ON-SITE WASTEWATER SYSTEMS

98.01 When Prohibited
98.02 When Required
98.03 Compliance with Regulations
98.04 Permit Required

98.05 Discharge Restrictions
98.06 Maintenance of System
98.07 Systems Abandoned
98.08 Disposal of Septage

98.01 WHEN PROHIBITED. Except as otherwise provided in this chapter, it is unlawful to construct or maintain any on-site wastewater treatment and disposal system or other facility intended or used for the disposal of sewage.

(Code of Iowa, Sec. 364.12[3f])

98.02 WHEN REQUIRED. When a public sanitary sewer is not available under the provisions of Section 95.05, every building wherein persons reside, congregate or are employed shall be provided with an approved on-site wastewater treatment and disposal system complying with the provisions of this chapter.

(567 IAC 69.1[3])

98.03 COMPLIANCE WITH REGULATIONS. The type, capacity, location, and layout of a private on-site wastewater treatment and disposal system shall comply with the specifications and requirements set forth by the Iowa Administrative Code 567, Chapter 69, and with such additional requirements as are prescribed by the regulations of the County Board of Health.

(567 IAC 69.1[3 and 4])

98.04 PERMIT REQUIRED.

1. No person shall install or alter an on-site wastewater treatment and disposal system without first obtaining a permit from the County Board of Health.
2. City Inspection. Where a public sanitary or combined sewer is not available, the building sewer shall be connected to a private sewage disposal system complying with the provisions of this section.

A. In addition to the County permit, the owner shall first obtain a written permit signed by the Superintendent. The permit applications shall be supplemented by any plans, specifications, or other information as are deemed necessary by the Superintendent. A permit and inspection fee of \$50.00 shall be paid to the City at the time the application is filed.

B. A permit for a private sewage disposal system shall not become effective until the installation is completed to the satisfaction of the Superintendent. They shall be allowed to inspect the work at any stage of construction, and, in any event, the applicant for the permit shall notify the Superintendent when the work is ready for final inspection, and before any underground portions are covered. The inspection shall be made within 48 hours of the receipt of notice by the Superintendent.

98.05 DISCHARGE RESTRICTIONS. It is unlawful to discharge any wastewater from an on-site wastewater treatment and disposal system (except under an NPDES permit) to any ditch, stream, pond, lake, natural or artificial waterway, drain tile or to the surface of the ground.
(567 IAC 69.1[3])

98.06 MAINTENANCE OF SYSTEM. The owner of an on-site wastewater treatment and disposal system shall operate and maintain the system in a sanitary manner at all times and at no expense to the City.

98.07 SYSTEMS ABANDONED. At such time as a public sewer becomes available to a property served by an on-site wastewater treatment and disposal system, as provided in Section 95.05, a direct connection shall be made to the public sewer in compliance with these Sanitary Sewer chapters and the on-site wastewater treatment and disposal system shall be abandoned and filled with suitable material.

(Code of Iowa, Sec. 364.12[3f])

98.08 DISPOSAL OF SEPTAGE. No person shall dispose of septage from an on-site treatment system at any location except an approved disposal site.

[The next page is 813]

CHAPTER 99

SEWER SERVICE CHARGES

99.01 Sewer Service Charges Required
99.02 Special Rates
99.03 Private Water Systems
99.04 Payment of Bills

99.05 Lien for Nonpayment
99.06 Deposit
99.07 Special Agreements Permitted

99.01 SEWER SERVICE CHARGES REQUIRED.

1. There shall be and there are established sewer service charges for the use of and for the service supplied by the municipal sanitary sewer utility based upon the amount and rate of water as follows:

1. Amount	1. Sewer Service Charge
2. Base Fee	2. \$27.50 per month (minimum monthly bill)
3. Usage Rate	3. \$5.30 per 1,000 gallons

2. In the case of non-metered services, the minimum service charge shall not be less than \$48.70 per month, which is necessary to retire the indebtedness, to pay operating, maintenance, and replacement costs, and to fund reserves necessary for maintaining the sanitary sewer facility.

3. Service to industrial establishments may be by contract if the City deems this to be in its best interest.

4. All of the above rates for sewer service charges shall be one and one half the rate for consumers who are served by this City sanitary sewer system and who receive this service at any location outside the City limits.

5. All of the rates for sewer services charges as set out in the above paragraphs of this section shall be one and one-half times the rate for sewer service provided to any household consumer who generates the sewage at a personal residence at any location outside the City limits.

6. All of the rates for sewer services charges as set out in the above paragraphs of this section shall be two times the rate for any commercial and industrial consumers who generate the waste deposited into the City sewer system from sources generated outside of the City limits.

99.02 SPECIAL RATES. Where, in the judgment of the Superintendent and the Council, special conditions exist to the extent that the application of the sewer charges provided in Section 99.01 would be inequitable or unfair to either the City or the customer, a special rate shall be proposed by the Superintendent and submitted to the Council for approval by resolution.

(Code of Iowa, Sec. 384.84)

99.03 PRIVATE WATER SYSTEMS. Customers whose premises are served by a private water system shall pay sewer charges based upon the water used as determined by the City either by an estimate agreed to by the customer or by metering the water system at the customer's expense. Any negotiated or agreed-upon sales or charges shall be subject to approval of the Council.

(Code of Iowa, Sec. 384.84)

99.04 PAYMENT OF BILLS. All sewer service charges are due and payable under the same terms and conditions provided for payment of a combined service account as contained in Section 92.04 of this Code of Ordinances. Sewer service may be discontinued or disconnected in accordance with the provisions contained in Section 92.05 if the combined service account becomes delinquent, and the provisions contained in Section 92.08 relating to lien notices shall also apply in the event of a delinquent account.

99.05 LIEN FOR NONPAYMENT. Except as provided for in Section 92.07 of this Code of Ordinances, the owner of the premises served and any lessee or tenant thereof shall be jointly and severally liable for sewer service charges to the premises. Sewer service charges remaining unpaid and delinquent shall constitute a lien upon the property or premises served and shall be certified by the Clerk to the County Treasurer for collection in the same manner as property taxes.

(Code of Iowa, Sec. 384.84)

99.06 DEPOSIT. (See Section 92.09)

99.07 SPECIAL AGREEMENTS PERMITTED. No statement in these chapters shall be construed as preventing a special agreement, arrangement, or contract between the Council, and any industrial concern whereby an industrial waste of unusual strength or character may be accepted subject to special conditions, rate, and cost as established by the Council.

[The next page is 863]

GARBAGE AND SOLID WASTE

TABLE OF CONTENTS

CHAPTER 105 - SOLID WASTE CONTROL	863
CHAPTER 106 - COLLECTION OF SOLID WASTE.....	873

CHAPTER 105

SOLID WASTE CONTROL

105.01 Purpose	105.07 Littering Prohibited
105.02 Definitions	105.08 Toxic and Hazardous Waste
105.03 Sanitary Disposal Required	105.09 Waste Storage Containers
105.04 Health and Fire Hazard	105.10 Prohibited Practices
105.05 Open Burning Restricted	105.11 Sanitary Disposal Project Designated
105.06 Separation of Yard Waste Required	

105.01 PURPOSE. The purpose of the chapters in this Code of Ordinances pertaining to Solid Waste Control and Collection is to provide for the sanitary storage, collection, and disposal of solid waste and, thereby, to protect the citizens of the City from such hazards to their health, safety, and welfare as may result from the uncontrolled disposal of solid waste.

105.02 DEFINITIONS. For use in these chapters the following terms are defined:

1. “Collector” means any person authorized to gather solid waste from public and private places.
2. “Discard” means to place, cause to be placed, throw, deposit, or drop.
(Code of Iowa, Sec. 455B.361[1])
3. “Dwelling unit” means any room or group of rooms located within a structure and forming a single habitable unit with facilities that are used or are intended to be used for living, sleeping, cooking, and eating.
4. “Garbage” means all solid and semisolid, putrescible animal and vegetable waste resulting from the handling, preparing, cooking, storing, serving, and consuming of food or of material intended for use as food, and all offal, excluding useful industrial by-products, and includes all such substances from all public and private establishments and from all residences.
(567 IAC 100.2)
5. “Landscape waste” means any vegetable or plant waste except garbage. The term includes trees, tree trimmings, branches, stumps, brush, weeds, leaves, grass, shrubbery, and yard trimmings.
(567 IAC 20.2)
6. “Litter” means any garbage, rubbish, trash, refuse, waste materials, or debris not exceeding 10 pounds in weight or 15 cubic feet in volume. Litter includes but is not limited to empty beverage containers, cigarette butts, food waste packaging, other food or candy wrappers, handbills, empty cartons, or boxes.
(Code of Iowa, Sec. 455B.361[2])
7. “Owner” means, in addition to the record titleholder, any person residing in, renting, leasing, occupying, operating, or transacting business in any premises, and as between such parties the duties, responsibilities, liabilities, and obligations hereinafter imposed shall be joint and several.

8. “Refuse” means putrescible and non-putrescible waste, including but not limited to garbage, rubbish, ashes, incinerator residues, street cleanings, market and industrial solid waste, and sewage treatment waste in dry or semisolid form.

(567 IAC 100.2)

9. “Residential premises” means a single-family dwelling and any multiple-family dwelling.

10. “Residential waste” means any refuse generated on the premises as a result of residential activities. The term includes landscape waste grown on the premises or deposited thereon by the elements, but excludes garbage, tires, trade wastes, and any locally recyclable goods or plastics.

(567 IAC 20.2)

11. “Rubbish” means non-putrescible solid waste consisting of combustible and non-combustible waste, such as ashes, paper, cardboard, tin cans, yard clippings, wood, glass, bedding, crockery, or litter of any kind.

(567 IAC 100.2)

12. “Sanitary disposal” means a method of treating solid waste so that it does not produce a hazard to the public health or safety or create a nuisance.

(567 IAC 100.2)

13. “Sanitary disposal project” means all facilities and appurtenances (including all real and personal property connected with such facilities) that are acquired, purchased, constructed, reconstructed, equipped, improved, extended, maintained, or operated to facilitate the final disposition of solid waste without creating a significant hazard to the public health or safety, and which are approved by the Director of the State Department of Natural Resources. “Sanitary disposal project” does not include a pyrolysis or gasification facility as defined in Section 455B.301 of the *Code of Iowa*.

(*Code of Iowa, Sec. 455B.301*)

14. “Solid waste” means garbage, refuse, rubbish, and other similar discarded solid or semisolid materials, including but not limited to such materials resulting from industrial, commercial, agricultural, and domestic activities. Solid waste may include vehicles, as defined by Section 321.1 of the *Code of Iowa*. Solid waste does not include any of the following:

(*Code of Iowa, Sec. 455B.301*)

A. Hazardous waste regulated under the Federal Resource Conservation and Recovery Act, 42 U.S.C. § 6921-6934.

B. Hazardous waste as defined in Section 455B.411 of the *Code of Iowa*, except to the extent that rules allowing for the disposal of specific wastes have been adopted by the State Environmental Protection Commission.

C. Source, special nuclear, or by-product material as defined in the Atomic Energy Act of 1954, as amended to January 1, 1979.

D. Petroleum contaminated soil that has been remediated to acceptable State or federal standards.

E. Steel slag which is a product resulting from the steel manufacturing process and is managed as an item of value in a controlled manner and not as a discarded material.

F. Material that is legitimately recycled pursuant to Section 455D.4A of the *Code of Iowa*.

G. Post-use polymers or recoverable feedstocks that are any of the following:

- (1) Processed at a pyrolysis or gasification facility.
- (2) Held at a pyrolysis or gasification facility prior to processing to ensure production is not interrupted.

15. “Toxic and hazardous waste” means waste materials, including (but not limited to) poisons, pesticides, herbicides, acids, caustics, pathological waste, flammable or explosive materials, and similar harmful waste that requires special handling and that must be disposed of in such a manner as to conserve the environment and protect the public health and safety.

(567 IAC 100.2)

16. “Yard waste” means any debris such as grass clippings, leaves, garden waste, brush, and trees. Yard waste does not include tree stumps.

105.03 SANITARY DISPOSAL REQUIRED. It is the duty of each owner to provide for the sanitary disposal of all refuse accumulating on the owner’s premises before it becomes a nuisance. Any such accumulation remaining on any premises for a period of more than 30 days shall be deemed a nuisance and the City may proceed to abate such nuisances in accordance with the provisions of Chapter 50 or by initiating proper action in district court.

(Code of Iowa, Ch. 657)

105.04 HEALTH AND FIRE HAZARD. It is unlawful for any person to permit to accumulate on any premises, improved or vacant, or on any public place, such quantities of solid waste that constitute a health, sanitation or fire hazard.

105.05 OPEN BURNING RESTRICTED. No person shall allow, cause, or permit open burning of combustible materials where the products of combustion are emitted into the open air without passing through a chimney or stack, except that open burning is permitted in the following circumstances:

(567 IAC 23.2 and 100.2)

1. Disaster Rubbish. The open burning of rubbish, including landscape waste, for the duration of the community disaster period in cases where an officially declared emergency condition exists, provided that the burning of any structures or demolished structures is conducted in accordance with 40 CFR Section 61.145.

(567 IAC 23.2[3] “a”)

2. Trees and Tree Trimmings. The open burning of trees and tree trimmings at a City-operated burning site, provided such burning is conducted in compliance with the rules established by the State Department of Natural Resources.

(567 IAC 23.2[3] “b”)

3. Landscape Waste. The disposal by open burning of landscape waste originating on the premises. However, the burning of landscape waste produced in clearing, grubbing, and construction operations shall be limited to areas located at least one-fourth mile from any building inhabited by other than the landowner or tenant conducting the open burning. Rubber tires shall not be used to ignite landscape waste.

(567 IAC 23.2[3] “d”)

4. Recreational Fires. Open fires for cooking, heating, recreation, and ceremonies, provided they comply with the limits for emission of visible air contaminants established by the State Department of Natural Resources. Rubber tires shall not be burned in a recreational fire.

(567 IAC 23.2[3]“e”)

5. Training Fires. Fires set for the purpose of conducting bona fide training of public or industrial employees in firefighting methods, provided that the training fires are conducted in compliance with rules established by the State Department of Natural Resources.

(567 IAC 23.2[3]“g”)

105.06 SEPARATION OF YARD WASTE REQUIRED. All yard waste shall be separated by the owner or occupant from all other solid waste accumulated on the premises and shall be composted on the premises or deposited, by the resident, at the City designated compost location.

105.07 LITTERING PROHIBITED. No person shall discard any litter onto or in any water or land, except that nothing in this section shall be construed to affect the authorized collection and discarding of such litter in or on areas or receptacles provided for such purpose. When litter is discarded from a motor vehicle, the driver of the motor vehicle shall be responsible for the act in any case where doubt exists as to which occupant of the motor vehicle actually discarded the litter.

(Code of Iowa, Sec. 455B.363)

105.08 TOXIC AND HAZARDOUS WASTE. No person shall deposit in a solid waste container or otherwise offer for collection any toxic or hazardous waste. Such materials shall be transported and disposed of as prescribed by the Director of the State Department of Natural Resources.

(567 IAC 100.2)

(567 IAC 102.13[2] and 400 IAC 27.14[2])

105.09 WASTE STORAGE CONTAINERS. Every person owning, managing, operating, leasing, or renting any premises, dwelling unit or any place where refuse accumulates shall provide and at all times maintain in good order and repair portable containers for refuse in accordance with the following:

1. Container Specifications. Waste storage and recycling containers are supplied by the contracting company. No other containers can be used.
2. Storage of Containers. Residential solid waste containers shall be stored upon the residential premises. Commercial solid waste containers shall be stored upon private property, unless the owner has been granted written permission from the City to use public property for such purposes. The storage site shall be well drained and fully accessible to collection equipment, public health personnel, and fire inspection personnel. All owners of residential and commercial premises shall be responsible for proper storage of all garbage and yard waste to prevent materials from being blown or scattered around neighboring yards and streets.
3. Location of Containers for Collection. Containers for the storage of solid waste awaiting collection shall be placed at the curb or alley line by the owner or occupant of the premises served. Containers or other solid waste placed at the curb line shall be promptly removed from the curb line following collection.

4. Nonconforming Containers. Solid waste placed in containers that are not in compliance with the provisions of this section will not be collected.

105.10 PROHIBITED PRACTICES. It is unlawful for any person to:

1. Unlawful Use of Containers. Deposit refuse in any solid waste containers not owned by such person without the written consent of the owner of such containers.
2. Interfere with Collectors. Interfere in any manner with solid waste collection equipment or with solid waste collectors in the lawful performance of their duties as such, whether such equipment or collectors be those of the City, or those of any other authorized waste collection service.
3. Incinerators. Burn rubbish or garbage except in incinerators designed for high temperature operation, in which solid, semisolid, liquid, or gaseous combustible refuse is ignited and burned efficiently, and from which the solid residues contain little or no combustible material, as acceptable to the Environmental Protection Commission.
4. Scavenging. Take or collect any solid waste that has been placed out for collection on any premises, unless such person is an authorized solid waste collector.

105.11 SANITARY DISPOSAL PROJECT DESIGNATED. The sanitary landfill facilities operated by SEMCO are hereby designated as the official "Public Sanitary Disposal Project" for the disposal of solid waste produced or originating within the City.

[The next page is 873]

CHAPTER 106

COLLECTION OF SOLID WASTE

106.01 Collection Service
106.02 Collection Vehicles
106.03 Loading
106.04 Frequency of Collection
106.05 Bulky Rubbish

106.06 Right of Entry
106.07 Contract Requirements
106.08 Collection Fees
106.09 Deposit
106.10 Lien for Nonpayment

106.01 COLLECTION SERVICE. The City shall provide by contract for the collection of solid waste, except bulky rubbish as provided in Section 106.05, from residential premises only. The owners or operators of commercial, industrial, or institutional premises shall provide for the collection of solid waste produced upon such premises.

106.02 COLLECTION VEHICLES. Vehicles or containers used for the collection and transportation of garbage and similar putrescible waste or solid waste containing such materials shall be leak-proof, durable and of easily cleanable construction. They shall be cleaned to prevent nuisances, pollution, or insect breeding and shall be maintained in good repair.

(567 IAC 104.9)

106.03 LOADING. Vehicles or containers used for the collection and transportation of any solid waste shall be loaded and moved in such a manner that the contents will not fall, leak, or spill therefrom, and shall be covered to prevent blowing or loss of material. Where spillage does occur, the material shall be picked up immediately by the collector or transporter and returned to the vehicle or container and the area properly cleaned.

106.04 FREQUENCY OF COLLECTION. All solid waste shall be collected from residential premises at least once each week and from commercial, industrial, and institutional premises as frequently as may be necessary, but not less than once each week. Recycling shall be collected every other week.

106.05 BULKY RUBBISH. Bulky rubbish that is too large or heavy to be collected in the normal manner of other solid waste may be collected by the collector upon request in accordance with procedures established by the Council.

106.06 RIGHT OF ENTRY. Solid waste collectors are hereby authorized to enter upon private property for the purpose of collecting solid waste, as required by this chapter; however, solid waste collectors shall not enter dwelling units or other residential buildings.

106.07 CONTRACT REQUIREMENTS. No person shall engage in the business of collecting, transporting, processing or disposing of solid waste from residential premises for the City without first entering into a contract with the City. This section does not prohibit an owner from transporting solid waste accumulating upon premises owned, occupied or used by such owner, provided such refuse is disposed of properly in an approved sanitary disposal project. Furthermore, a contract is not required for the removal, hauling, or disposal of earth and rock material from grading or excavation activities, provided that all such materials are conveyed in tight vehicles, trucks or receptacles so constructed and maintained that none of the material being transported is spilled upon any public right-of-way.

106.08 COLLECTION FEES. The collection and disposal of solid waste as provided by this chapter are declared to be beneficial to the property served or eligible to be served and there shall be levied and collected fees for the same, in accordance with the following:

(Goreham vs. Des Moines, 1970, 179 NW 2nd, 449 [Iowa 1970])

1. Fee for Collection. Each household is charged a basic fee of \$27.50 per month for garbage pickup. Included in the basic fee is a limit of one garbage can and one recycling bin. All garbage must be in a garbage can. *(Ord. 2-2024 – May 24 Supp.)*
2. In the event of a vacancy of a business or residence, the minimum fee of \$27.50 shall be assessed. If the utilities of water and electricity for any business or residence are disconnected and garbage receptacles are moved, then no fee shall be assessed for that business place or residence. *(Ord. 2-2024 – May 24 Supp.)*
3. Payment of Bills. All fees are due and payable under the same terms and conditions provided for payment of a combined service account as contained in Section 92.04 of this Code of Ordinances. Solid waste collection service may be discontinued in accordance with the provisions contained in Section 92.05 if the combined service account becomes delinquent, and the provisions contained in Section 92.08 relating to lien notices shall also apply in the event of a delinquent account.

106.09 DEPOSIT. (See Section 92.09)

(Code of Iowa, Sec. 384.84)

106.10 LIEN FOR NONPAYMENT. Except as provided for in Section 92.07 of this Code of Ordinances, the owner of the premises served and any lessee or tenant thereof are jointly and severally liable for fees for solid waste collection and disposal. Fees remaining unpaid and delinquent shall constitute a lien upon the property or premises served and shall be certified by the Clerk to the County Treasurer for collection in the same manner as property taxes.

(Code of Iowa, Sec. 384.84)

[The next page is 907]

FRANCHISES AND OTHER SERVICES

TABLE OF CONTENTS

CHAPTER 110 - NATURAL GAS FRANCHISE	907
CHAPTER 111 - ELECTRIC FRANCHISE	915

CHAPTER 110

NATURAL GAS FRANCHISE

110.01 Franchise Granted	110.10 Information
110.02 Rights and Privileges	110.11 Applicable Regulations
110.03 Pipes and Mains	110.12 Term of Franchise
110.04 Construction and Maintenance	110.13 Regulation and Enforcement
110.05 Excavation	110.14 Franchise Fee
110.06 Utility Easements	110.15 Management Fees
110.07 Relocation Not Required	110.16 Termination
110.08 Relocation Reimbursement	110.17 Validity
110.09 Indemnification	110.18 Assignment

110.01 FRANCHISE GRANTED. There is hereby granted to MidAmerican Energy Company, an Iowa corporation, (hereinafter called “Company”), and to its successors and assigns the right and franchise to acquire, construct, erect, maintain, and operate in the City of Hedrick, Iowa, (hereinafter called the “City”), a gas distribution system, to furnish natural gas along, under and upon the right-of-way, streets, avenues, alleys, and public places to serve customers within and without the City and to furnish and sell natural gas to the City and its inhabitants. For the term of this franchise, the Company is granted the right of eminent domain, the exercise of which is subject to Council approval upon application by the Company. This franchise shall be effective for a 25-year period from and after the effective date of this chapter.†

110.02 RIGHTS AND PRIVILEGES. The rights and privileges hereby granted are subject to the restrictions and limitations of chapter 364 of the *Code of Iowa* 2017, or as subsequently amended or changed.

110.03 PIPES AND MAINS. Company shall have the right to excavate in any public street for the purpose of laying, relaying, repairing, or extending gas pipes, mains, conduits, and other facilities provided that the same shall be so placed as not to unreasonably interfere with any above or below-ground utility services or facilities which have been or may hereafter be located by or under authority of the City.

110.04 CONSTRUCTION AND MAINTENANCE. Company shall, excluding facilities located in private easements (whether titled in Company exclusively or in Company and other entities), in accordance with State law including Company tariff on file and made effective by the Iowa Utilities Board as may subsequently be amended (“Tariff”), at its cost and expense, locate and relocate its existing facilities or equipment in, on, over or under any public street or alley in the City in such a manner as the City may reasonably require for the purposes of facilitating the construction, reconstruction, maintenance, or repair of the street or alley. Relocation expenses for other hard surfaces, including pedestrian and non-motorized vehicle pathways, will be paid by the City. If the City has a reasonable alternative route for the street, alley, or public improvements or an alternative construction method, which would not cause the relocation of Company installations, the City shall select said alternative route, or construction method. The City shall be responsible for surveying and staking the right-of-way for City projects that require Company to relocate Company facilities. If requested the City shall provide, at no cost to Company, copies of its relocation plan and profile and cross section

† **EDITOR’S NOTE:** Ordinance No. 1-2017, adopting a natural gas franchise for the City, was passed and adopted on November 6, 2017.

drawings. If tree and vegetation removal must be completed by the City as part of the City's project and are necessary whether or not utility facilities must be relocated, the City, at its own, cost shall be responsible for said removals. If the timing of the tree/vegetation removal does not coincide with the Company facilities relocation schedule and Company must remove trees/vegetation that are included in the City's portion of the project, the City shall either remove the material at its cost or reimburse Company for the expenses incurred to remove said vegetation or trees. If project funds from a source other than the City are available to pay for the relocation of utility facilities, the City shall attempt to secure said funds and provide them to Company to compensate Company for the costs of relocation.

110.05 EXCAVATION. In making excavations in any streets, avenues, alleys, and public places for the installation of gas pipes, conduits, or apparatus, Company shall not unreasonably obstruct the use of the streets and shall replace the surface, restoring it to the condition as existed immediately prior to excavation. Company agrees any replacement of road surface shall conform to current City Code regarding its depth and composition. Company shall not be required to restore or modify public right-of-way, sidewalks, or other areas in or adjacent to Company project to a condition superior to its immediate previously existing condition or to a condition exceeding its previously existing condition to the extent any alterations are required for the City to comply with City, State, or federal rules, regulations, or laws.

110.06 UTILITY EASEMENTS. The City's vacating a street, avenue, alley, public ground, or public right-of-way shall not deprive Company of its right to operate and maintain existing facilities on, below, above, or beneath the vacated property. Prior to the City abandoning or vacating any street, avenue, alley, or public ground where the Company has facilities in the vicinity, the City shall provide Company with not less than 60 days advance notice of the City's proposed action and, upon request, grant the Company a utility easement covering existing and future facilities and activities. If the City fails to grant the Company a utility easement for said facilities prior to abandoning or vacating a street, avenue, alley, or public ground the City shall, at its cost and expense, obtain easements for the existing Company facilities.

110.07 RELOCATION NOT REQUIRED. Company shall not be required to relocate, at its cost and expense, Company facilities in the public right-of-way that have been relocated at Company expense at the direction of the City at any time during the previous 10 years.

110.08 RELOCATION REIMBURSEMENT. Pursuant to relocation of Company facilities as may be required hereunder, if the City orders or requests Company to relocate its existing facilities or equipment in order to directly or indirectly facilitate the project of a commercial or private developer or other non-public entity, City shall reimburse, or the City shall require the developer or non-public entity to reimburse, Company for the cost of such relocation as a precondition to relocation. The Company shall not be required to relocate in order to facilitate such private project at its expense.

110.09 INDEMNIFICATION. Company shall indemnify and save harmless the City from any and all claims, suits, losses, damages, costs, or expenses, on account of injury or damage to any person or property, to the extent caused or occasioned by Company's negligence in construction, reconstruction, excavation, operation, or maintenance of the natural gas facilities authorized by this franchise; provided, however that the Company shall not be obligated to defend, indemnify and save harmless the City for any costs or damages to the extent arising from the negligence of the City, its officers, employees, or agents.

110.10 INFORMATION. Upon reasonable request, Company shall provide the City, on a project specific basis, information indicating the horizontal location, relative to boundaries of the right-of-way, of all equipment which it owns or over which it has control that is located in the public right-of-way, including documents, maps, and other information in paper or electronic or other forms (“Information”). Company and City recognize the information may, in whole or part, be considered a confidential record under State or federal law or both. Upon receipt of a request from a third party for information concerning information about Company’s facilities within the City, the City will promptly submit same to Company. If Company believes any of the information requested constitutes a trade secret which may be protected from public disclosure by State or federal law, or otherwise exempt from disclosure under the provisions of the Freedom of Information Act, the Federal Energy Regulatory Commission Critical Energy Infrastructure requirements pursuant to 18 CFR 388.112 and 388.113 or Chapter 22 of the *Code of Iowa*, as such statutes and regulations may be amended from time to time, then the Company shall provide the City with a written explanation of the basis for such assertion of confidentiality or exemption from disclosure within 10 days.

110.11 APPLICABLE REGULATIONS. Company shall extend its mains and pipes and operate, and shall maintain the system in accordance with applicable regulations of the Iowa Utilities Board or its successors and State law.

110.12 TERM OF FRANCHISE. During the term of this franchise, Company shall furnish natural gas in the quantity and quality consistent with and in accordance with the applicable regulations of the Iowa Utilities Board, the Company’s tariff made effective by the Iowa Utilities Board or its successors, and State law.

110.13 REGULATION AND ENFORCEMENT. All reasonable and proper police regulations shall be adopted and enforced by the City for the protection of the facilities of the Company.

110.14 FRANCHISE FEE. A franchise fee of zero percent is imposed upon, and shall be collected from, the natural gas customers of the Company receiving service and located within the corporate limits of the City. The franchise fee shall be imposed upon the gross receipts, minus uncollectible accounts, generated from sales of natural gas and distribution service:

1. The City agrees to modify the level of franchise fees imposed only once in any 24- month period.
2. Company will commence collecting franchise fees on or before the first Company billing cycle of the first calendar month following 90 days of receipt of information required of the City to implement the franchise fee, including the City’s documentation of customer classes subject to or exempted from the City imposed franchise fee.
3. The City shall be solely responsible for identifying customer classes subject to or exempt from paying the City imposed franchise fee. Company shall have no obligation to collect franchise fees from customers in annexed areas until and unless such ordinances have been provided to Company by certified mail. Company shall commence collecting franchise fees in the annexed areas no sooner than 60 days after receiving annexation ordinances from the City.
4. Company shall not, under any circumstances be required to return or refund any franchise fees that have been collected from customers and remitted to the City. In the event the Company is required to provide data or information in defense of the

City's imposition of franchise fees or the Company is required to assist the City in identifying customers or calculating any franchise fee refunds for groups of or individual customers, the City shall reimburse the Company for the expenses incurred by the Company to provide such data or information.

110.15 MANAGEMENT FEES. Upon implementation of a franchise fee the City shall not, pursuant to Chapter 480A.6 of the *Code of Iowa*, impose or charge Company right-of-way management fees for permits for Company construction, maintenance, repairs, excavation, pavement cutting, or inspections of Company work sites and projects or related matters.

110.16 TERMINATION. Either City or Company ("party") may terminate this franchise if the other party shall be materially in breach of its provisions. Upon the occurrence of a material breach, the non-breaching party shall provide the breaching party with notification by certified mail specifying the alleged breach. The breaching party shall have 60 days to cure the breach, unless it notifies the non-breaching party, and the parties agree upon a shorter or longer period for cure. If the breach is not cured within the cure period, the non-breaching party may terminate this franchise. A party shall not be considered to be in breach of this franchise if it has operated in compliance with State or federal law. A party shall not be considered to have breached this franchise if the alleged breach is the result of the actions of a third party or the other party.

110.17 VALIDITY. If any section, provision, or part of this chapter shall be adjudged to be invalid or unconstitutional, such adjudication shall not affect the validity of the chapter as a whole or any section, provision, or part thereof not adjudged invalid or unconstitutional.

110.18 ASSIGNMENT. This chapter and the rights and privileges herein granted shall become effective and binding upon its approval and passage in accordance with Iowa law and the written acceptance by Company. The City shall provide Company with an original signed and sealed copy of this chapter within 10 days of its final passage. Company shall, within 30 days after Council approval of this chapter, file in the office of the Clerk, its acceptance in writing of all terms and provisions of this chapter. Following Council approval, this chapter shall be published in accordance with the *Code of Iowa*. The effective date of this chapter shall be the date of publication. In the event that Company does not file its written acceptance of this chapter within 30 days after its approval by the Council, this chapter shall be void and of no effect.

[The next page is 915]

CHAPTER 111

ELECTRIC FRANCHISE

111.01 Franchise Granted	111.06 Continuous Service
111.02 Construction; Maintenance; Indemnification	111.07 Term of Franchise
111.03 Duty to Furnish	111.08 Publication Expense
111.04 Modern Services	111.09 Franchise Accepted
111.05 Nonexclusive	111.10 Entire Agreement

111.01 FRANCHISE GRANTED. There is hereby granted to IES Utilities Inc., hereinafter referred to as the “Company,” its successors and assigns, the right and franchise to acquire, construct, erect, maintain, and operate in the City of Hedrick, Keokuk County, Iowa, works and plants for the manufacture and generation of electricity and a distribution system for electric light, heat, and power and the right to erect and maintain the necessary poles, lines, wires, conduits, and other appliances for the transmission of electric current along, under, and upon the streets, avenues, alleys, and public places in the said City of Hedrick, Keokuk County, Iowa; also the right to erect and maintain upon the streets, avenues, alleys, and public places, transmission lines through the said City of Hedrick, Keokuk County, Iowa, to supply individuals, corporations, communities, and municipalities both inside and outside of said City with electric light, heat, and power for the period of 25 years; also the right of eminent domain as provided in Section 364.2 of the *Code of Iowa*.[†]

111.02 CONSTRUCTION; MAINTENANCE; INDEMNIFICATION. The poles, wires, and appliances shall be placed and maintained so as not to unnecessarily interfere with the travel on said streets, alleys, and public places in said City nor unnecessarily interfere with the proper use of the same, including ordinary drainage, or with the sewers, underground pipe and other property of the City, and the said Company, its successors and assigns, shall hold the City free and harmless from all damages arising from the negligent acts or omissions of the Company in the erection or maintenance of said system.

111.03 DUTY TO FURNISH. The Company, its successors, and assigns, shall furnish and install all meters at its own expense, and shall provide the service wire to buildings as set forth in the Company’s tariff filed with the Iowa Utilities Board.

111.04 MODERN SERVICES. The system authorized by this chapter shall be modern and up-to-date and shall be of sufficient capacity to supply all reasonable demands of said City and its inhabitants thereof and shall be kept in a modern and up-to-date condition.

111.05 NONEXCLUSIVE. The franchise granted by this chapter shall not be exclusive.

111.06 CONTINUOUS SERVICE. Service to be rendered by the Company under this franchise shall be continuous unless prevented from doing so by fire, Acts of God, unavoidable accidents or casualties, or reasonable interruptions necessary to properly service the Company’s equipment, and in such event service shall be resumed as quickly as is reasonably possible.

[†] **EDITOR’S NOTE:** Ordinance No. 2-2001, adopting an electric franchise for the City, was passed and adopted on July 20, 2001.

111.07 TERM OF FRANCHISE. The term of the franchise granted by this chapter and the rights granted thereunder shall continue for the period of 25 years from and after its acceptance by the said Company, as herein provided.

111.08 PUBLICATION EXPENSE. The expense of the publication of this chapter and the expense of the election herein called shall be paid by the Company, its successors, and assigns.

111.09 FRANCHISE ACCEPTED. The franchise granted by this chapter shall be conditioned upon acceptance by the Company in writing. The acceptance shall be filed with the Clerk within 90 days from Company receiving a majority of the votes cast at the election hereinafter called.

111.10 ENTIRE AGREEMENT. This chapter sets forth and constitutes the entire agreement between the Company and the City with respect to the rights contained herein, and may not be superceded, modified, or otherwise amended without approval by qualified electors at a special election. Notwithstanding the foregoing, in no event shall the City enact any ordinance or place any limitations, either operationally or through the assessment of fees, that create additional burdens upon the Company, or which delay utility operations.

[The next page is 989]

REGULATION OF BUSINESS AND VOCATIONS

TABLE OF CONTENTS

CHAPTER 120 - LIQUOR LICENSES AND WINE AND BEER PERMITS	989
CHAPTER 121 - CIGARETTE AND TOBACCO PERMITS	997
CHAPTER 122 - PEDDLERS, SOLICITORS, AND TRANSIENT MERCHANTS	1005
CHAPTER 123 - HOUSE MOVERS	1011
CHAPTER 124 - JUNK DEALERS	1017

CHAPTER 120

LIQUOR LICENSES AND WINE AND BEER PERMITS

120.01 License or Permit Required
120.02 General Prohibition
120.03 Investigation

120.04 Action by Council
120.05 Prohibited Sales and Acts
120.06 Amusement Devices

120.01 LICENSE OR PERMIT REQUIRED. No person shall manufacture for sale, import, sell, or offer or keep for sale, alcoholic liquor, wine, or beer without first securing a retail alcohol license, wine permit, or beer permit in accordance with the provisions of Chapter 123 of the *Code of Iowa*.

(Code of Iowa, Sec. 123.22, 123.122, and 123.171)

120.02 GENERAL PROHIBITION. It is unlawful to manufacture for sale, sell, offer, or keep for sale, possess, or transport alcoholic liquor, wine, or beer except upon the terms, conditions, limitations, and restrictions enumerated in Chapter 123 of the *Code of Iowa*, and a license or permit may be suspended or revoked or a civil penalty may be imposed for a violation thereof.

(Code of Iowa, Sec. 123.2, 123.39, and 123.50)

120.03 INVESTIGATION. Upon receipt of an application for a retail alcohol license, the Clerk may forward it to the Police Chief, who shall then conduct an investigation and submit a written report as to the truth of the facts averred in the application. The Fire Chief may also inspect the premises to determine if they conform to the requirements of the City. The Council shall not approve an application for a license for any premises that does not conform to the applicable law and ordinances, resolutions, and regulations of the City.

(Code of Iowa, Sec. 123.30)

120.04 ACTION BY COUNCIL. The Council shall either approve or disapprove the issuance of a retail alcohol license, shall endorse its approval or disapproval on the application, and shall forward the application with the necessary fee and bond, if required, to the Iowa Department of Revenue.

(Code of Iowa, Sec. 123.32[2])

120.05 PROHIBITED SALES AND ACTS. A person holding a retail alcohol license and the person's agents or employees shall not do any of the following:

1. Sell, dispense, or give to any intoxicated person, or one simulating intoxication, any alcoholic beverage.

(Code of Iowa, Sec. 123.49[1])

2. Sell or dispense any alcoholic beverage on the premises covered by the license, or permit its consumption thereon between the hours of 2:00 a.m. and 6:00 a.m. on any day of the week.

(Code of Iowa, Sec. 123.49[2b])

3. Sell alcoholic beverages to any person on credit, except with a bona fide credit card. This provision does not apply to sales by a club to its members, to sales by a hotel

or motel to bona fide registered guests, or to retail sales by the managing entity of a convention center, civic center, or events center.

(Code of Iowa, Sec. 123.49[2c])

4. Employ a person under 18 years of age in the sale or serving of alcoholic beverages for consumption on the premises where sold, except as follows:

A. Definitions. For use in this subsection the following terms are defined as follows:

(1) “Bar” means an establishment where one may purchase alcoholic beverages for consumption on the premises and in which the serving of food is only incidental to the consumption of those beverages.

(Code of Iowa, Sec. 142D.2[1])

(2) “Restaurant” means eating establishments, including private and public school cafeterias, which offer food to the public, guests, or employees, including the kitchen and catering facilities in which food is prepared on the premises for serving elsewhere, and including a bar area within a restaurant.

(Code of Iowa, Sec. 142D.2[17])

B. This subsection shall not apply if the employer has, on file, written permission from the parent, guardian, or legal custodian of a person 16 or 17 years of age for the person to sell or serve alcoholic beverages for consumption on the premises where sold. However, a person 16 or 17 years of age shall not work in a bar as defined in Paragraph A.

(1) The employer shall keep a copy of the written permission on file until the person is either 18 years of age or no longer engaged in the sale of or serving alcoholic beverages for consumption on the premises where sold.

(2) If written permission is on file in accordance with Paragraph B, a person 16 or 17 years of age may sell or serve alcoholic beverages in a restaurant as defined above in Paragraph A during the hours in which the restaurant serves food.

C. A person 16 or 17 years of age shall not sell or serve alcoholic beverages under this subsection unless at least two employees 18 years of age or older are physically present in the area where alcoholic beverages are sold or served.

D. If a person employed under this subsection reports an incident of workplace harassment to the employer or if the employer otherwise becomes aware of such an incident, the employer shall report the incident to the employee’s parent, guardian, or legal custodian and to the Iowa Civil Rights Commission, which shall determine if any action is necessary or appropriate under Chapter 216 of the *Code of Iowa*.

E. An employer that employs a person under this subsection shall require the person to attend training on prevention and response to sexual harassment upon commencing employment.

F. Prior to a person commencing employment under this subsection, the employer shall notify the employer’s dramshop liability insurer, in a form and

time period prescribed by the Director, that the employer is employing a person under this subsection.

(Code of Iowa, Sec. 123.49[2f])

5. In the case of a retail wine or beer permittee, knowingly allow the mixing or adding of alcohol or any alcoholic beverage to wine, beer, or any other beverage in or about the permittee's place of business.

(Code of Iowa, Sec. 123.49[2i])

6. Knowingly permit any gambling, except in accordance with Iowa law, or knowingly permit any solicitation for immoral purposes, or immoral or disorderly conduct on the premises covered by the license.

(Code of Iowa, Sec. 123.49[2a])

7. Knowingly permit or engage in any criminal activity on the premises covered by the license.

(Code of Iowa, Sec. 123.49[2j])

8. Keep on premises covered by a retail alcohol license any alcoholic liquor in any container except the original package purchased from the Iowa Department of Revenue and except mixed drinks or cocktails mixed on the premises for immediate consumption. However, mixed drinks or cocktails that are mixed on the premises and are not for immediate consumption may be consumed on the licensed premises, subject to rules adopted by the Iowa Department of Revenue.

(Code of Iowa, Sec. 123.49[2d])

9. Reuse for packaging alcoholic liquor or wine any container or receptacle used originally for packaging alcoholic liquor or wine; or adulterate, by the addition of any substance, the contents, or remaining contents of an original package of an alcoholic liquor or wine; or knowingly possess any original package that has been reused or adulterated.

(Code of Iowa, Sec. 123.49[2e])

10. Allow any person other than the licensee or employees of the licensee to use or keep on the licensed premises any alcoholic liquor in any bottle or other container that is designed for the transporting of such beverages, except as allowed by State law.

(Code of Iowa, Sec. 123.49[2g])

11. Sell, give, possess, or otherwise supply a machine that is used to vaporize an alcoholic beverage for the purpose of being consumed in a vaporized form.

(Code of Iowa, Sec. 123.49[2k])

12. Permit or allow any person under 21 years of age to remain upon licensed premises unless over 50 percent of the dollar volume of the business establishment comes from the sale and serving of prepared foods. This provision does not apply to holders of a Class "B" beer permit or an establishment employee when employed in compliance with State law.

120.06 AMUSEMENT DEVICES. The following provisions pertain to electrical or mechanical amusement devices possessed and used in accordance with Chapter 99B of the *Code of Iowa*. (Said devices are allowed only in premises with a retail alcohol license, as specifically authorized in said Chapter 99B.)

(Code of Iowa, Sec. 99B.57)

1. As used in this section, "registered electrical or mechanical amusement device" means an electrical or mechanical device required to be registered with the Iowa

Department of Inspection and Appeals, as provided in Section 99B.53 of the *Code of Iowa*.

2. It is unlawful for any person under the age of 21 to participate in the operation of a registered electrical or mechanical amusement device.
3. It is unlawful for any person owning or leasing a registered electrical or mechanical amusement device, or an employee of a person owning or leasing a registered electrical or mechanical amusement device, to knowingly allow a person under the age of 21 to participate in the operation of a registered electrical or mechanical amusement device.
4. It is unlawful for any person to knowingly participate in the operation of a registered electrical or mechanical amusement device with a person under the age of 21.

[The next page is 997]

CHAPTER 121

CIGARETTE AND TOBACCO PERMITS

121.01 Definitions
121.02 Permit Required
121.03 Application
121.04 Fees
121.05 Issuance and Expiration

121.06 Refunds
121.07 Persons Under Legal Age
121.08 Self-Service Sales Prohibited
121.09 Permit Revocation

121.01 DEFINITIONS. For use in this chapter the following terms are defined:
(Code of Iowa, Sec. 453A.1)

1. “Alternative nicotine product” means a product, not consisting of or containing tobacco, that provides for the ingestion into the body of nicotine, whether by chewing, absorbing, dissolving, inhaling, snorting, or sniffing, or by any other means. “Alternative nicotine product” does not include cigarettes, tobacco products, or vapor products, or a product that is regulated as a drug or device by the United States Food and Drug Administration under Chapter V of the Federal Food, Drug, and Cosmetic Act.
2. “Cigarette” means any roll for smoking made wholly or in part of tobacco, or any substitute for tobacco, irrespective of size or shape and irrespective of tobacco or any substitute for tobacco being flavored, adulterated, or mixed with any other ingredient, where such roll has a wrapper or cover made of paper or any other material. However, cigarette shall not be construed to include cigars.
3. “Place of business” means any place where cigarettes, tobacco products, alternative nicotine products, or vapor products are sold, stored, or kept for the purpose of sale or consumption by a retailer.
4. “Retailer” means every person who sells, distributes, or offers for sale for consumption, or possesses for the purpose of sale for consumption, cigarettes, alternative nicotine products, or vapor products, irrespective of the quantity or amount or the number of sales, or who engages in the business of selling tobacco, tobacco products, alternative nicotine products, or vapor products to ultimate consumers.
5. “Self-service display” means any manner of product display, placement, or storage from which a person purchasing the product may take possession of the product, prior to purchase, without assistance from the retailer or employee of the retailer, in removing the product from a restricted access location.
6. “Tobacco products” means the following: cigars; little cigars; cheroots; stogies; periques; granulated, plug cut, crimp cut, ready rubbed, and other smoking tobacco; snuff; cavendish; plug and twist tobacco; fine-cut and other chewing tobaccos; shorts or refuse scraps, clippings, cuttings, and sweepings of tobacco; and other kinds and forms of tobacco prepared in such manner as to be suitable for chewing or smoking in a pipe or otherwise, or for both chewing and smoking, but does not mean cigarettes.
7. “Vapor product” means any noncombustible product, which may or may not contain nicotine, that employs a heating element, power source, electronic circuit, or other electronic, chemical, or mechanical means, regardless of shape or size, that can be used to produce vapor from a solution or other substance. “Vapor product” includes

an electronic cigarette, electronic cigar, electronic cigarillo, electronic pipe, or similar product or device, and any cartridge or other container of a solution or other substance, which may or may not contain nicotine, that is intended to be used with or in an electronic cigarette, electronic cigar, electronic cigarillo, electronic pipe, or similar product or device. “Vapor product” does not include a product regulated as a drug or device by the United States Food and Drug Administration under Chapter V of the Federal Food, Drug, and Cosmetic Act.

121.02 PERMIT REQUIRED.

1. Retail Cigarette Permits. It is unlawful for any person, other than a holder of a retail permit, to sell cigarettes, alternative nicotine products, or vapor products at retail and no retailer shall distribute, sell, or solicit the sale of any cigarettes, alternative nicotine products, or vapor products within the City without a valid permit for each place of business. The permit shall, at all times, be publicly displayed at the place of business so as to be easily seen by the public and the persons authorized to inspect the place of business.

(Code of Iowa, Sec. 453A.13)

2. Retail Tobacco Permits. It is unlawful for any person to engage in the business of a retailer of tobacco, tobacco products, alternative nicotine products, or vapor products at any place of business without first having received a permit as a retailer for each place of business owned or operated by the retailer.

(Code of Iowa, Sec. 453A.47A)

A retailer who holds a retail cigarette permit is not required to also obtain a retail tobacco permit. However, if a retailer only holds a retail cigarette permit and that permit is suspended, revoked, or expired, the retailer shall not sell any tobacco, tobacco products, alternative nicotine products, or vapor products, during such time.

121.03 APPLICATION. A completed application on forms furnished by the State Department of Revenue or on forms made available or approved by the Department and accompanied by the required fee shall be filed with the Clerk. Renewal applications shall be filed at least five days prior to the last regular meeting of the Council in June. If a renewal application is not timely filed, and a special Council meeting is called to act on the application, the costs of such special meeting shall be paid by the applicant.

(Code of Iowa, Sec. 453A.13 and 453A.47A)

121.04 FEES. The fee for a retail cigarette or tobacco permit shall be as follows:

(Code of Iowa, Sec. 453A.13 and 453A.47A)

FOR PERMITS GRANTED DURING:	FEE:
July, August, or September	\$ 75.00
October, November, or December	\$ 56.25
January, February, or March	\$ 37.50
April, May, or June	\$ 18.75

121.05 ISSUANCE AND EXPIRATION. Upon proper application and payment of the required fee, a permit shall be issued. Each permit issued shall describe clearly the place of business for which it is issued and shall be nonassignable. All permits expire on June 30 of each year. The Clerk shall submit a duplicate of any application for a permit to the Iowa Department of Revenue within 30 days of issuance of a permit.

121.06 REFUNDS. A retailer may surrender an unrevoked permit and receive a refund from the City, except during April, May, or June, in accordance with the schedule of refunds as provided in Section 453A.13 or 453A.47A of the *Code of Iowa*.

(Code of Iowa, 453A.13 and 453A.47A)

121.07 PERSONS UNDER LEGAL AGE. A person shall not sell, give, or otherwise supply any tobacco, tobacco products, alternative nicotine products, vapor products, or cigarettes to any person under 21 years of age. The provision of this section includes prohibiting a person under 21 years of age from purchasing tobacco, tobacco products, alternative nicotine products, vapor products, and cigarettes from a vending machine. If a retailer or employee of a retailer violates the provisions of this section, the Council shall, after written notice and hearing, and in addition to the other penalties fixed for such violation, assess the following:

1. For a first violation, the retailer shall be assessed a civil penalty in the amount of \$300.00. Failure to pay the civil penalty as ordered under this subsection shall result in automatic suspension of the permit for a period of 14 days.
2. For a second violation within a period of two years, the retailer shall be assessed a civil penalty in the amount of \$1,500.00 or the retailer's permit shall be suspended for a period of 30 days. The retailer may select its preference in the penalty to be applied under this subsection.
3. For a third violation within a period of three years, the retailer shall be assessed a civil penalty in the amount of \$1,500.00 and the retailer's permit shall be suspended for a period of 30 days.
4. For a fourth violation within a period of three years, the retailer shall be assessed a civil penalty in the amount of \$1,500.00 and the retailer's permit shall be suspended for a period of 60 days.
5. For a fifth violation within a period of four years, the retailer's permit shall be revoked.

The Clerk shall give 10 days' written notice to the retailer by mailing a copy of the notice to the place of business as it appears on the application for a permit. The notice shall state the reason for the contemplated action and the time and place at which the retailer may appear and be heard.

(Code of Iowa, Sec. 453A.2, 453A.22, and 453A.36[6])

121.08 SELF-SERVICE SALES PROHIBITED. Except for the sale of cigarettes through a cigarette vending machine as provided in Section 453A.36[6] of the *Code of Iowa*, a retailer shall not sell or offer for sale tobacco, tobacco products, alternative nicotine products, vapor products, or cigarettes through the use of a self-service display.

(Code of Iowa, Sec. 453A.36A)

121.09 PERMIT REVOCATION. Following a written notice and an opportunity for a hearing, as provided by the *Code of Iowa*, the Council may also revoke a permit issued pursuant to this chapter for a violation of Division I of Chapter 453A of the *Code of Iowa* or any rule adopted thereunder. If a permit is revoked, a new permit shall not be issued to the permit holder for any place of business, or to any other person for the place of business at which the violation occurred, until one year has expired from the date of revocation, unless good cause to the contrary is shown to the Council. The Clerk shall report the revocation or suspension of a retail permit to the Alcoholic Beverages Division of the Department of Commerce within 30 days of the revocation or suspension.

(Code of Iowa, Sec. 453A.22)

[The next page is 1005]

CHAPTER 122

PEDDLERS, SOLICITORS, AND TRANSIENT MERCHANTS

122.01 Definitions

122.02 Exemptions

122.03 Hours of Solicitation

122.04 Consumer Protection Law

122.05 Obstruction of Pedestrian or Vehicular Traffic

122.01 DEFINITIONS. For purposes of this chapter the following terms are defined:

1. “Peddler” means any person carrying or transporting goods or merchandise who sells or offers for sale for immediate delivery such goods or merchandise from house-to-house or upon the public street.
2. “Solicitor” means any person who solicits or attempts to solicit from house-to-house or upon public streets orders for commercial goods, wares, subscriptions, publications, periodicals, merchandise, or services to be delivered or fulfilled at a future date. For the purposes of this chapter, solicitor does not include a person who contacts another person at such person’s residence without prior invitation to enlist support for or against, or solicit funds for patriotic, philanthropic, charitable, political, or religious purposes, whether or not there is an incidental purpose involving the sale of some goods or service.
3. “Transient merchant” means every merchant, whether an individual person, a firm, corporation, partnership, or association, who brings or causes to be brought within the municipality any goods, wares, or merchandise of any kind, nature, or description, with the intention of temporarily or intermittently selling or offering to sell at retail such goods, wares, or merchandise. Temporary association with a local merchant, dealer, trader, or auctioneer, for conducting such transient business in connection with, as part of, or in the name of any local merchant, dealer, trader, or auctioneer, does not exempt any such person, firm, or corporation from being considered a transient merchant.

The provisions of this chapter shall not be construed to apply to persons selling at wholesale to merchants, nor to persons running a huckster wagon, or selling or distributing livestock feeds, fresh meats, fish, fruit, or vegetables, nor to persons selling their own work or production either by themselves or their employees.

122.02 EXEMPTIONS. The provisions of this chapter shall not apply to nonprofit civic, charitable, religious, or educational groups engaged in retail sale for the purposes of fund raising.

122.03 HOURS OF SOLICITATION. No person may conduct those activities described in Section 122.01 except between the hours of 9:00 a.m. and 6:00 p.m. on each day, and no solicitation shall be done on Sundays or legal holidays.

122.04 CONSUMER PROTECTION LAW. All solicitors and peddlers shall be informed to agree to comply with the State law, Section 555A.3 of the *Code of Iowa*, requiring a notice of cancellation to be given in duplicate, properly filled out, to each buyer to whom such person sells a product or service and, comply with the other requirements of the law.

122.05 OBSTRUCTION OF PEDESTRIAN OR VEHICULAR TRAFFIC. No person, while engaged in any of the practices described in Section 122.01, shall block or obstruct the path of any pedestrian or vehicular traffic, or block or obstruct any way of ingress or egress to roads, buildings, or other enclosures or conveyances, including, but not limited to, vehicles, elevators, and escalators.

[The next page is 1011]

CHAPTER 123

HOUSE MOVERS

123.01 House Mover Defined
123.02 Permit Required
123.03 Application
123.04 Bond Required
123.05 Insurance Required
123.06 Permit Fee

123.07 Permit Issued
123.08 Public Safety
123.09 Time Limit
123.10 Removal by City
123.11 Protect Pavement
123.12 Overhead Wires

123.01 HOUSE MOVER DEFINED. A “house mover” means any person who undertakes to move a building or similar structure upon, over or across public streets or property when the building or structure is of such size that it requires the use of skids, jacks, dollies, or any other specialized moving equipment.

123.02 PERMIT REQUIRED. It is unlawful for any person to engage in the activity of house mover as herein defined without a valid permit from the City for each house, building, or similar structure to be moved.

123.03 APPLICATION. Application for a house mover’s permit shall be made in writing to the Clerk on a form provided by the City. The application shall include:

1. Name and Address. The applicant’s full name and address and, if a corporation, the names and addresses of its principal officers.
2. Building Location. An accurate description of the present location and future site of the building or similar structure to be moved.
3. Routing Plan. A routing plan approved by the Mayor, street superintendent, and public utility officials. The route approved shall be the shortest route compatible with the greatest public convenience and safety.

123.04 BOND REQUIRED. The applicant shall post with the Clerk a penal bond in the minimum sum of \$5,000.00 issued by a surety company authorized to issue such bonds in the State. The bond shall guarantee the permittee’s payment for any damage done to the City or to public property, and payment of all costs incurred by the City in the course of moving the building or structure.

123.05 INSURANCE REQUIRED. Each applicant shall also file a certificate of insurance indicating that the applicant is carrying public liability insurance in effect for the duration of the permit covering the applicant and all agents and employees for the following minimum amounts:

1. Bodily Injury – \$50,000.00 per person; \$100,000.00 per accident.
2. Property Damage – \$50,000.00 per accident.

123.06 PERMIT FEE. A permit fee of \$300.00 shall be payable at the time of filing the application with the Clerk. A separate permit shall be required for each house, building or similar structure to be moved.

123.07 PERMIT ISSUED. Upon approval of the application, filing of bond and insurance certificate, and payment of the required fee, the Clerk shall issue a permit.

123.08 PUBLIC SAFETY. At all times when a building or similar structure is in motion upon any street, alley, sidewalk, or public property, the permittee shall maintain flag persons at the closest intersections or other possible channels of traffic to the sides, behind, and ahead of the building or structure. At all times when the building or structure is at rest upon any street, alley, sidewalk, or public property the permittee shall maintain adequate warning signs or lights at the intersections or channels of traffic to the sides, behind, and ahead of the building or structure.

123.09 TIME LIMIT. No house mover shall permit or allow a building or similar structure to remain upon any street or other public way for a period of more than 12 hours without having first secured the written approval of the City.

123.10 REMOVAL BY CITY. In the event any building or similar structure is found to be in violation of Section 123.09, the City is authorized to remove such building or structure and assess the costs thereof against the permit holder and the surety on the permit holder's bond.

123.11 PROTECT PAVEMENT. It is unlawful to move any house or building of any kind over any pavement, unless the wheels or rollers upon which the house or building is moved are at least one inch in width for each 1,000 pounds of weight of such building. If there is any question as to the weight of a house or building, the estimate of the City as to such weight shall be final.

123.12 OVERHEAD WIRES. The holder of any permit to move a building shall see that all telephone, cable television, and electric wires and poles are removed when necessary and replaced in good order, and shall be liable for the costs of the same.

[The next page is 1017]

CHAPTER 124

JUNK DEALERS

124.01 Definitions	124.07 Revocation of License
124.02 License Required	124.08 Notice of Hearing
124.03 Persons Entitled to be Licensed	124.09 Location
124.04 License Fee	124.10 Requirements and Regulations
124.05 Investigation; Inspection	124.11 Concealing Property
124.06 Transfer Prohibited	

124.01 DEFINITIONS. For purposes of this chapter, the following terms are defined:

1. “Junk” means old or secondhand vehicles, machinery, iron, or other materials, rope, rags, glass, fabric, cordage, wood, or paper not suitable for sale for the purpose for which the same was originally fabricated, but which is salvageable so as to be used again in some manner.
2. “Junk dealer” means any person engaged in the business of collecting, storing, buying, or selling junk, including the activity known as “auto salvage.”

124.02 LICENSE REQUIRED. It is unlawful for any person to engage in the vocation of junk dealer in the City without having a license as herein provided.

124.03 PERSONS ENTITLED TO BE LICENSED. Any person who satisfies the conditions prescribed for a license and satisfies the Council that said person’s operation does not and will not endanger the public welfare, order, safety, health, or morals is entitled to a license upon filing of proper application and paying the full fee required.

124.04 LICENSE FEE. The license fee is \$5.00 per annum and said license shall expire one year after date of issue.

124.05 INVESTIGATION; INSPECTION. The City shall have the power to inspect and investigate the conduct of the occupation licensed or to be licensed under this chapter or to cause such an inspection or investigation to be made by the peace officer.

124.06 TRANSFER PROHIBITED. In no case shall a license issued hereunder be transferable to another person or used for any purposes other than that for which it was issued.

124.07 REVOCATION OF LICENSE. The Council may, after giving the licensee reasonable notice and a fair hearing, revoke any license issued under this chapter for the following reasons:

1. The licensee has made fraudulent statements in the application for the license or in the conduct of the licensee’s business.
2. The licensee has violated this chapter or has otherwise conducted the licensee’s business in an unlawful manner.
3. The licensee has conducted the licensee’s business in a manner endangering the public welfare, health, safety, order, or morals.

124.08 NOTICE OF HEARING. The notice of hearing on revocation of a license shall be in writing and shall be served personally or as required for personal service by the State Rule of Civil Procedure. The notice shall state the time and place of hearing and the reasons for the intended revocation.

124.09 LOCATION. The business of junk dealer shall not be located within 500 feet of any building used for business or residential purposes to a location approved by the City.

124.10 REQUIREMENTS AND REGULATIONS. Applicants for a license under this chapter shall comply with the following requirements and regulations:

1. Minors. A junk dealer shall not purchase or receive junk from a minor unless the dealer first receives the written consent of the parents or guardian of the minor. Such consent shall be attached to the record book as a part of the permanent record.
2. Inspection by Peace Officer. In order to discover stolen property, the peace officer shall be permitted to inspect the junk dealer's yard, store, or establishment at all reasonable hours.
3. Public Health. The County Health Officer shall be permitted at all reasonable times to inspect the junk dealer's premises for the existence of materials or conditions dangerous to the public health.
4. Fence Required. All junk yards shall be enclosed within a solid fence at least eight feet in height, which fence shall be painted white. Materials within the yard shall not be stacked higher than the surrounding fence. Any gates in such fence shall be of solid material and of equal height.
5. Burning Restricted. The burning of materials giving off offensive odors or smoke in quantities which are objectionable is prohibited, and State air pollution control laws shall be complied with.

124.11 CONCEALING PROPERTY. It is unlawful for any junk dealer to conceal or secrete any article purchased or received by such dealer for the purpose of preventing identification thereof by any peace officer or by any person claiming the ownership of same.

[The next page is 1107]

STREETS AND SIDEWALKS

TABLE OF CONTENTS

CHAPTER 135 - STREET USE AND MAINTENANCE	1107
CHAPTER 136 - SIDEWALK REGULATIONS.....	1115
CHAPTER 137 - VACATION AND DISPOSAL OF STREETS	1123
CHAPTER 138 - STREET GRADES	1129
CHAPTER 139 - NAMING OF STREETS.....	1135

CHAPTER 135

STREET USE AND MAINTENANCE

135.01 Removal of Warning Devices

135.02 Obstructing or Defacing

135.03 Placing Debris On

135.04 Playing In

135.05 Traveling On Barricaded Street or Alley

135.06 Use for Business Purposes

135.07 Washing Vehicles

135.08 Burning Prohibited

135.09 Excavations

135.10 Property Owner's Responsibility for Maintenance

135.11 Failure to Maintain

135.12 Dumping of Snow

135.13 Driveway Culverts

135.01 REMOVAL OF WARNING DEVICES. It is unlawful for a person to willfully remove, throw down, destroy, or carry away from any street or alley any lamp, obstruction, guard, or other article or things, or extinguish any lamp or other light, erected or placed thereupon for the purpose of guarding or enclosing unsafe or dangerous places in said street or alley without the consent of the person in control thereof.

(Code of Iowa, Sec. 716.1)

135.02 OBSTRUCTING OR DEFACING. It is unlawful for any person to obstruct, deface or injure any street or alley in any manner.

(Code of Iowa, Sec. 716.1)

135.03 PLACING DEBRIS ON. It is unlawful for any person to throw or deposit on any street or alley any glass, glass bottle, nails, tacks, wire, cans, trash, garbage, rubbish, litter, offal, leaves, grass, or any other debris likely to be washed into the storm sewer and clog the storm sewer, or any substance likely to injure any person, animal, or vehicle.

(Code of Iowa, Sec. 321.369)

135.04 PLAYING IN. It is unlawful for any person to coast, sled, or play games on streets or alleys, except in the areas blocked off by the City for such purposes.

(Code of Iowa, Sec. 364.12[2])

135.05 TRAVELING ON BARRICADED STREET OR ALLEY. It is unlawful for any person to travel or operate any vehicle on any street or alley temporarily closed by barricades, lights, signs, or flares placed thereon by the authority or permission of any City official, police officer, or member of the Fire Department.

135.06 USE FOR BUSINESS PURPOSES. It is unlawful to park, store or place, temporarily or permanently, any machinery or junk or any other goods, wares, and merchandise of any kind upon any street or alley for the purpose of storage, exhibition, sale, or offering same for sale, without permission of the Council.

135.07 WASHING VEHICLES. It is unlawful for any person to use any public sidewalk, street, or alley for the purpose of washing or cleaning any automobile, truck equipment, or any vehicle of any kind when such work is done for hire or as a business. This does not prevent any person from washing or cleaning his or her own vehicle or equipment when it is lawfully parked in the street or alley.

135.08 BURNING PROHIBITED. No person shall burn any trash, leaves, rubbish, or other combustible material in any curb and gutter or on any paved or surfaced street or alley.

135.09 EXCAVATIONS. No person shall dig, excavate, or in any manner disturb any street, parking, or alley except in accordance with the following:

1. Permit Required. No excavation shall be commenced without first obtaining a permit. A written application for such permit shall be filed with the City and shall contain the following:
 - A. An exact description of the property, by lot and street number, in front of or along which it is desired to excavate;
 - B. A statement of the purpose, for whom and by whom the excavation is to be made;
 - C. The person responsible for the refilling of said excavation and restoration of the street or alley surface; and
 - D. Date of commencement of the work and estimated completion date.
2. Public Convenience. Streets and alleys shall be opened in the manner that will cause the least inconvenience to the public and admit the uninterrupted passage of water along the gutter on the street.
3. Barricades, Fencing, and Lighting. Adequate barricades, fencing, and warning lights meeting standards specified by the City shall be so placed as to protect the public from hazard. Any costs incurred by the City in providing or maintaining adequate barricades, fencing, or warning lights shall be paid to the City by the permit holder/property owner.
4. Bond Required. The applicant shall post with the City a penal bond in the minimum sum of \$1,000.00 issued by a surety company authorized to issue such bonds in the State. The bond shall guarantee the permittee's payment for any damage done to the City or to public property, and payment of all costs incurred by the City in the course of administration of this section. In lieu of a surety bond, a cash deposit of \$1,000.00 may be filed with the City.
5. Insurance Required. Each applicant shall also file a certificate of insurance indicating that the applicant is carrying public liability insurance in effect for the duration of the permit covering the applicant and all agents and employees for the following minimum amounts:
 - A. Bodily Injury - \$50,000.00 per person; \$100,000.00 per accident.
 - B. Property Damage - \$50,000.00 per accident.
6. Restoration of Public Property. Streets, sidewalks, alleys, and other public property disturbed in the course of the work shall be restored to the condition of the property prior to the commencement of the work, or in a manner satisfactory to the City, at the expense of the permit holder/property owner.
7. Inspection. All work shall be subject to inspection by the City. Backfill shall not be deemed completed, and no resurfacing of any improved street or alley surface shall begin, until such backfill is inspected and approved by the City. The permit holder/property owner shall provide the City with notice at least 24 hours prior to the time when inspection of backfill is desired.

8. Completion by the City. Should any excavation in any street or alley be discontinued or left open and unfinished for a period of 24 hours after the approved completion date, or in the event the work is improperly done, the City has the right to finish or correct the excavation work and charge any expenses for such work to the permit holder/property owner.
9. Responsibility for Costs. All costs and expenses incident to the excavation shall be borne by the permit holder or property owner. The permit holder and owner shall indemnify the City from any loss or damage that may directly or indirectly be occasioned by such excavation.
10. Notification. At least 48 hours prior to the commencement of the excavation, excluding Saturdays, Sundays, and legal holidays, the person performing the excavation shall contact the Statewide Notification Center and provide the center with the information required under Section 480.4 of the *Code of Iowa*.
11. Permit Fee. A permit fee of \$25.00 shall be payable at the time of filing the application with the City. A separate permit shall be required for each excavation.
12. Permit Issued. Upon approval of the application, filing of bond and insurance certificate, and payment of any required fees, a permit shall be issued.

135.10 PROPERTY OWNER'S RESPONSIBILITY FOR MAINTENANCE. The abutting property owner shall maintain all property outside the lot and property lines and inside the curb lines upon public streets and shall keep such area in a safe condition, free from nuisances, obstructions, and hazards. In the absence of a curb, such property shall extend from the property line to that portion of the public street used or improved for vehicular purposes. The abutting property owner shall not be required to remove diseased trees or dead wood on the publicly owned property or right-of-way. Maintenance includes, but is not limited to, timely mowing, trimming trees and shrubs, and picking up litter and debris. The abutting property owner may be liable for damages caused by failure to maintain the publicly owned property or right-of-way.[†]

(Code of Iowa, Sec. 364.12[2c])

135.11 FAILURE TO MAINTAIN. If the abutting property owner does not perform an action required under the above section within a reasonable time, the City may perform the required action and assess the cost against the abutting property for collection in the same manner as a property tax.

(Code of Iowa, Sec. 364.12[2e])

135.12 DUMPING OF SNOW. It is unlawful for any person to throw, push, or place or cause to be thrown, pushed or placed, any ice or snow from private property, sidewalks, or driveways onto the traveled way of a street or alley so as to obstruct gutters, or impede the passage of vehicles upon the street or alley or to create a hazardous condition therein; except where, in the cleaning of large commercial drives in the Business District it is absolutely necessary to move the snow onto the street or alley temporarily, such accumulation shall be removed promptly by the property owner or agent. Arrangements for the prompt removal of such accumulations shall be made prior to moving the snow.

(Code of Iowa, Sec. 364.12[2])

[†] **EDITOR'S NOTE:** See also Section 136.04 relating to property owner's responsibility for maintenance of sidewalks.

135.13 DRIVEWAY CULVERTS. The property owner shall, at the owner's expense, install any culvert deemed necessary under any driveway or any other access to the owner's property, and before installing a culvert, permission must first be obtained from the City. In the event repairs are needed at any time with respect to culverts, it shall be the responsibility of the property owner to make such repairs, and, in the event the owner fails to do so, the City shall have the right to make repairs. If the property owner fails to reimburse the City for the cost of said repairs, the cost shall be certified to the County Treasurer and specially assessed against the property as by law provided. *(Ord. 6-2024 – Sep. 24 Supp.)*

[The next page is 1115]

CHAPTER 136

SIDEWALK REGULATIONS

136.01 Purpose	136.10 Failure to Repair or Barricade
136.02 Definitions	136.11 Interference with Sidewalk Improvements
136.03 Removal of Snow, Ice, and Accumulations	136.12 Encroaching Steps
136.04 Property Owner's Responsibility for Maintenance	136.13 Openings and Enclosures
136.05 City May Order Repairs	136.14 Fires or Fuel on Sidewalks
136.06 Sidewalk Construction Ordered	136.15 Defacing
136.07 Permit Required	136.16 Debris on Sidewalks
136.08 Sidewalk Standards	136.17 Merchandise Display
136.09 Barricades and Warning Lights	136.18 Sales Stands

136.01 PURPOSE. The purpose of this chapter is to enhance safe passage by citizens on sidewalks, to place the responsibility for the maintenance, repair, replacement, or reconstruction of sidewalks upon the abutting property owner and to minimize the liability of the City.

136.02 DEFINITIONS. For use in this chapter the following terms are defined:

1. "Broom finish" means a sidewalk finish that is made by sweeping the sidewalk when it is hardening.
2. "Established grade" means that grade established by the City for the particular area in which a sidewalk is to be constructed.
3. "One-course construction" means that the full thickness of the concrete is placed at one time, using the same mixture throughout.
4. "Owner" means the person owning the fee title to property abutting any sidewalk and includes any contract purchaser for purposes of notification required herein. For all other purposes, "owner" includes the lessee, if any.
5. "Portland cement" means any type of cement except bituminous cement.
6. "Sidewalk" means all permanent public walks in business, residential or suburban areas.
7. "Sidewalk improvements" means the construction, reconstruction, repair, replacement, or removal of a public sidewalk or the excavating, filling, or depositing of material in the public right-of-way in connection therewith.
8. "Wood float finish" means a sidewalk finish that is made by smoothing the surface of the sidewalk with a wooden trowel.

136.03 REMOVAL OF SNOW, ICE, AND ACCUMULATIONS. The abutting property owner shall remove snow, ice, and accumulations promptly from sidewalks. If a property owner does not remove snow, ice, or accumulations within a reasonable time, the City may do so and assess the costs against the property owner for collection in the same manner as a property tax. The abutting property owner may be liable for damages caused by failure to remove snow, ice, and accumulations promptly from the sidewalk.

(Code of Iowa, Sec. 364.12[2b and e])

136.04 PROPERTY OWNER'S RESPONSIBILITY FOR MAINTENANCE. The abutting property owner shall maintain in a safe and hazard-free condition any sidewalk outside

the lot and property lines and inside the curb lines or, in the absence of a curb, any sidewalk between the property line and that portion of the public street used or improved for vehicular purposes. The abutting property owner may be liable for damages caused by failure to maintain the sidewalk.

(Code of Iowa, Sec. 364.12[2c])

136.05 CITY MAY ORDER REPAIRS. If the abutting property owner does not maintain sidewalks as required, the Council may serve notice on such owner, by certified mail, requiring the owner to repair, replace or reconstruct sidewalks within a reasonable time and if such action is not completed within the time stated in the notice, the Council may require the work to be done and assess the costs against the abutting property for collection in the same manner as a property tax.

(Code of Iowa, Sec. 364.12[2d and e])

136.06 SIDEWALK CONSTRUCTION ORDERED. The Council may order the construction of permanent sidewalks upon any street or court in the City and may specially assess the cost of such improvement to abutting property owners in accordance with the provisions of Chapter 384 of the *Code of Iowa*.

(Code of Iowa, Sec. 384.38)

136.07 PERMIT REQUIRED. No person shall remove, reconstruct, or install a sidewalk unless such person has obtained a permit from the City and has agreed in writing that said removal, reconstruction, or installation will comply with all ordinances and requirements of the City for such work. A written application for such permit shall be filed with the City and shall be accompanied by a permit fee of \$25.00.

136.08 SIDEWALK STANDARDS. Sidewalks repaired, replaced, or constructed under the provisions of this chapter shall be of the following construction and meet the following standards:

1. Cement. Portland cement shall be the only cement used in the construction and repair of sidewalks.
2. Construction. Sidewalks shall be of one-course construction.
3. Sidewalk Base. Concrete may be placed directly on compact and well-drained soil. Where soil is not well drained, a three-inch sub-base of compact, clean, coarse gravel or sand shall be laid. The adequacy of the soil drainage is to be determined by the City.
4. Sidewalk Bed. The sidewalk bed shall be so graded that the constructed sidewalk will be at established grade.
5. Length, Width and Depth. Length, width and depth requirements are as follows:
 - A. Residential sidewalks shall be at least four feet wide and four inches thick, and each section shall be no more than four feet in length.
 - B. Business District sidewalks shall extend from the property line to the curb. Each section shall be four inches thick and no more than six feet in length.
 - C. Driveway areas shall be not less than six inches in thickness.

6. Location. Residential sidewalks shall be located with the inner edge (edge nearest the abutting private property) on the property line, unless the Council establishes a different distance due to special circumstances.
7. Grade. Curb tops shall be on level with the centerline of the street, which is the established grade.
8. Elevations. The street edge of a sidewalk shall be at an elevation even with the curb at the curb or not less than one-half inch above the curb for each foot between the curb and the sidewalk.
9. Slope. All sidewalks shall slope one-fourth inch per foot toward the curb.
10. Finish. All sidewalks shall be finished with a broom finish or wood float finish.
11. Curb Ramps and Sloped Areas for Persons with Disabilities. If a street, road, or highway is newly built or reconstructed, a curb ramp or sloped area shall be constructed or installed at each intersection of the street, road, or highway with a sidewalk or path. If a sidewalk or path is newly built or reconstructed, a curb ramp or sloped area shall be constructed or installed at each intersection of the sidewalk or path with a street, highway, or road. Curb ramps and sloped areas that are required pursuant to this subsection shall be constructed or installed in compliance with applicable federal requirements adopted in accordance with the Federal Americans with Disabilities Act, including (but not limited to) the guidelines issued by the Federal Architectural and Transportation Barriers Compliance Board.

(Code of Iowa, Sec. 216C.9)

136.09 BARRICADES AND WARNING LIGHTS. Whenever any material of any kind is deposited on any street, avenue, highway, passageway or alley when sidewalk improvements are being made or when any sidewalk is in a dangerous condition, it shall be the duty of all persons having an interest therein, either as the contractor or the owner, agent, or lessee of the property in front of or along which such material may be deposited, or such dangerous condition exists, to put in conspicuous places at each end of such sidewalk and at each end of any pile of material deposited in the street, a sufficient number of approved warning lights or flares, and to keep them lighted during the entire night and to erect sufficient barricades both at night and in the daytime to secure the same. The party or parties using the street for any of the purposes specified in this chapter shall be liable for all injuries or damage to persons or property arising from any wrongful act or negligence of the party or parties, or their agents or employees or for any misuse of the privileges conferred by this chapter or of any failure to comply with provisions hereof.

136.10 FAILURE TO REPAIR OR BARRICADE. It is the duty of the owner of the property abutting the sidewalk, or the owner's contractor or agent, to notify the City immediately in the event of failure or inability to make necessary sidewalk improvements or to install or erect necessary barricades as required by this chapter.

136.11 INTERFERENCE WITH SIDEWALK IMPROVEMENTS. No person shall knowingly or willfully drive any vehicle upon any portion of any sidewalk or approach thereto while in the process of being improved or upon any portion of any completed sidewalk or approach thereto, or shall remove or destroy any part or all of any sidewalk or approach thereto, or shall remove, destroy, mar, or deface any sidewalk at any time or destroy, mar, remove, or deface any notice provided by this chapter.

136.12 ENCROACHING STEPS. It is unlawful for a person to erect or maintain any stairs or steps to any building upon any part of any sidewalk without permission by resolution of the Council.

136.13 OPENINGS AND ENCLOSURES. It is unlawful for a person to:

1. Stairs and Railings. Construct or build a stairway or passageway to any cellar or basement by occupying any part of the sidewalk, or to enclose any portion of a sidewalk with a railing without permission by resolution of the Council.
2. Openings. Keep open any cellar door, grating, or cover to any vault on any sidewalk except while in actual use with adequate guards to protect the public.
3. Protect Openings. Neglect to properly protect or barricade all openings on or within six feet of any sidewalk.

136.14 FIRES OR FUEL ON SIDEWALKS. It is unlawful for a person to make a fire of any kind on any sidewalk or to place or allow any fuel to remain upon any sidewalk.

136.15 DEFACING. It is unlawful for a person to scatter or place any paste, paint, or writing on any sidewalk.

(Code of Iowa, Sec. 716.1)

136.16 DEBRIS ON SIDEWALKS. It is unlawful for a person to throw or deposit on any sidewalk any glass, nails, glass bottle, tacks, wire, cans, trash, garbage, rubbish, litter, offal, or any other debris, or any substance likely to injure any person, animal, or vehicle.

(Code of Iowa, Sec. 364.12[2])

136.17 MERCHANDISE DISPLAY. It is unlawful for a person to place upon or above any sidewalk, any goods or merchandise for sale or for display in such a manner as to interfere with the free and uninterrupted passage of pedestrians on the sidewalk; in no case shall more than three feet of the sidewalk next to the building be occupied for such purposes.

136.18 SALES STANDS. It is unlawful for a person to erect or keep any vending machine or stand for the sale of fruit, vegetables or other substances or commodities on any sidewalk without first obtaining a written permit from the Council.

[The next page is 1123]

CHAPTER 137

VACATION AND DISPOSAL OF STREETS

137.01 Power to Vacate

137.02 Planning and Zoning Commission

137.03 Notice of Vacation Hearing

137.04 Findings Required

137.05 Disposal of Vacated Streets or Alleys

137.06 Disposal by Gift Limited

137.01 POWER TO VACATE. When, in the judgment of the Council, it would be in the best interest of the City to vacate a street, alley, portion thereof, or any public grounds, the Council may do so by ordinance in accordance with the provisions of this chapter.

(Code of Iowa, Sec. 364.12[2a])

137.02 PLANNING AND ZONING COMMISSION. Any proposal to vacate a street, alley, portion thereof, or any public grounds shall be referred by the Council to the Planning and Zoning Commission for its study and recommendation prior to further consideration by the Council. The Commission shall submit a written report including recommendations to the Council within 30 days after the date the proposed vacation is referred to the Commission.

(Code of Iowa, Sec. 392.1)

137.03 NOTICE OF VACATION HEARING. The Council shall cause to be published a notice of public hearing of the time at which the proposal to vacate shall be considered.

137.04 FINDINGS REQUIRED. No street, alley, portion thereof, or any public grounds shall be vacated unless the Council finds that:

1. Public Use. The street, alley, portion thereof, or any public ground proposed to be vacated is not needed for the use of the public, and therefore, its maintenance at public expense is no longer justified.
2. Abutting Property. The proposed vacation will not deny owners of property abutting on the street or alley reasonable access to their property.

137.05 DISPOSAL OF VACATED STREETS OR ALLEYS. When in the judgment of the Council it would be in the best interest of the City to dispose of a vacated street or alley, portion thereof or public ground, the Council may do so in accordance with the provisions of Section 364.7, *Code of Iowa*.

(Code of Iowa, Sec. 364.7)

137.06 DISPOSAL BY GIFT LIMITED. The City may not dispose of real property by gift except to a governmental body for a public purpose or to a fair.

(Code of Iowa, Sec. 174.15[2] and 364.7[3])

CHAPTER 138

STREET GRADES

138.01 Purpose and Definition

138.03 Record Maintained

138.02 Established Grades

138.01 PURPOSE AND DEFINITION. This chapter is designed to meet the requirements of the *Code of Iowa* for the establishment of street grades. As used herein, “grade” means the longitudinal reference lines, as established by ordinance of the Council, which designate the elevation at which a street or sidewalk is to be built.

138.02 ESTABLISHED GRADES. The grades of all streets, alleys, and sidewalks, which have been heretofore established by ordinance, are hereby confirmed, ratified, and established as official grades.

138.03 RECORD MAINTAINED. The Clerk shall maintain a record of all established grades and furnish information concerning such grades upon request.

EDITOR’S NOTE

The following ordinances not codified herein, and specifically saved from repeal, have been adopted establishing street or sidewalk grades and remain in full force and effect.

ORDINANCE NO.	ADOPTED	ORDINANCE NO.	ADOPTED
1929	February 6, 1928		
Grade Ordinance	February 6, 1928		

[The next page is 1135]

CHAPTER 139

NAMING OF STREETS

139.01 Naming New Streets
139.02 Changing Name of Street
139.03 Recording Street Names

139.04 Official Street Name Map
139.05 Revision of Street Name Map

139.01 NAMING NEW STREETS. New streets shall be assigned names in accordance with the following:

1. Extension of Existing Street. Streets added to the City that are natural extensions of existing streets shall be assigned the name of the existing street.
2. Ordinance. All street names, except streets named as a part of a subdivision or platting procedure, shall be named by ordinance.
3. Planning and Zoning Commission. Proposed street names shall be referred to the Planning and Zoning Commission for review and recommendation.

139.02 CHANGING NAME OF STREET. The Council may, by ordinance, change the name of a street.

139.03 RECORDING STREET NAMES. Following official action naming or changing the name of a street, the Clerk shall file a copy thereof with the County Recorder, County Auditor, and County Assessor.

(Code of Iowa, Sec. 354.26)

139.04 OFFICIAL STREET NAME MAP. Streets within the City are named as shown on the Official Street Name Map, which is hereby adopted by reference and declared to be a part of this chapter. The Official Street Name Map shall be identified by the signature of the Mayor, and bearing the seal of the City under the following words: "This is to certify that this is the Official Street Name Map referred to in Section 139.04 of the Code of Ordinances of Hedrick, Iowa."

139.05 REVISION OF STREET NAME MAP. If in accordance with the provisions of this chapter, changes are made in street names, such changes shall be entered on the Official Street Name Map promptly after the amendment has been approved by the Council with an entry on the Official Street Name Map as follows: "On (date), by official action of the City Council, the following changes were made in the Official Street Name Map: (brief description)," which entry shall be signed by the Mayor and attested by the Clerk. No amendment to this chapter which involves naming or changing the name of a street shall become effective until after such change and entry have been made on said map.

EDITOR'S NOTE	
The following ordinances not codified herein, and specifically saved from repeal, have been adopted establishing or changing street names and remain in full force and effect.	
NAMED STREETS OR ORDINANCE NO.	DESCRIPTION OR ADOPTED
Main Street.	The street running north from the south corporate limits at Wapello County Road and ending at Sixth Street, also known as Highway 149, shall be called Main Street.
Lake Street.	The street running north from the south corporate limits, ending at Second Street, thence beginning again beyond Sixth Street, and continuing north to Railroad Avenue, beyond whence it becomes a County road, shall be called Lake Street.
Prairie Avenue.	The street running north from Second Street in Wycoff's addition and ending at Sixth Street shall be called Prairie Avenue.
Twin Street.	The street running one block north from First Street to Second Street in Bottorff's addition shall be called Twin Street.
Waugh Street.	The street running north and south in Bottorff's addition beginning one block south of First Street and continuing north to Sixth Street shall be called Waugh Street.
West Street.	The street running north beginning at First Street and continuing to north corporate limits in Hagan's addition, one block west of Waugh Street, shall be called West Street.
Spring Street.	The street running north beginning at First Street and continuing to north corporate limits in Hagan's addition, one block east of West Street, shall be known as Spring Street.
Park Street.	The street running north from First Street to Fifth Street between Main Street and East Street shall be called Park Street.
East Street.	The street beginning one block south of First Street and continuing north to Fifth Street shall be called East Street.
Young Street.	The street beginning at Second Street and continuing north to Sixth Street, one block east of East Street, shall be called Young Street.
Hursey Street.	The street variously misspelled Hersey, Hershey, Hirsey, and Hirchy, one block east of Brooks Street and running north from Second Street to Sixth Street, shall be called correctly Hursey Street.
Waldo Street.	The street running north from Second Street to Sixth Street, one block east of Hursey Street, shall be called Waldo Street.
First Street.	The street running east from South Lake Street and ending at South East Street shall be called First Street.
Second Street.	The street running east from Prairie Avenue to corporate limits at Agency County Road shall be called Second Street.
Third Street.	The street running east from one block west of Waugh Street and continuing to Hursey Street shall be called Third Street.
Fourth Street.	The street running east from one block west of Waugh Street ending at Spring Street, thence continuing again east from Main Street to Waldo Street, shall be called Fourth Street.
Fifth Street.	The street running east from Main Street and ending at the east corporate limits shall be called Fifth Street.
Sixth Street.	The portion of Highway 149 running east from the west corporate limits to the east corporate limits shall continue to be also called Sixth Street.

<p>NAMED STREETS OR ORDINANCE NO.</p>	<p>DESCRIPTION OR ADOPTED</p>
<p>Gray Street.</p>	<p>The street running east one block from West Street to Spring Street, one block from West Street to Spring Street, one block north of Sixth Street in Hagan’s addition, formerly referred to as Gay Street, shall herea fter be known as Gray Street.</p>
<p>Worth Street.</p>	<p>The street running east from West Street to Spring Street, one block north of Gray Street in Hagan’s addition, shall herea fter be known as North Street.</p>
<p>South Street.</p>	<p>The street one block south of First Street running east from Main Street to East Street in Morrison’s addition shall herea fter be known as South Street.</p>
<p>Half Street.</p>	<p>The passage alley running north from Second Street and ending at Fourth Street, west of Waugh Street, shall be called Half Street.</p>
<p>Perkins Drive.</p>	<p>The street beginning at Second Street east of the high school gymnasium in Wycoff’s addition and running north to a dead-end at the east gymnasium parking lot shall be called Perkins Drive.</p>
<p></p>	<p></p>
<p></p>	<p></p>
<p></p>	<p></p>
<p></p>	<p></p>

[The next page is 1189]

BUILDING AND PROPERTY REGULATIONS

TABLE OF CONTENTS

CHAPTER 145 - DANGEROUS BUILDINGS	1189
CHAPTER 146 - MANUFACTURED AND MOBILE HOMES	1197
CHAPTER 147 - PROPERTY MAINTENANCE CODE	1203
CHAPTER 148 - RENTAL PERMIT PROCESS	1205
CHAPTER 150 - BUILDING NUMBERING	1229
CHAPTER 151 - TREES.....	1235

CHAPTER 145

DANGEROUS BUILDINGS

145.01 Enforcement Officer

145.02 General Definition of Unsafe

145.03 Unsafe Building

145.04 Notice to Owner

145.05 Conduct of Hearing

145.06 Posting of Signs

145.07 Right to Demolish; Municipal Infraction

145.08 Costs

145.01 ENFORCEMENT OFFICER. The Mayor is responsible for the enforcement of this chapter.

145.02 GENERAL DEFINITION OF UNSAFE. All buildings or structures that are structurally unsafe or not provided with adequate egress, or that constitute a fire hazard, or are otherwise dangerous to human life, or that in relation to existing use constitute a hazard to safety or health, or public welfare, by reason of inadequate maintenance, dilapidation, obsolescence, or abandonment, are, for the purpose of this chapter, unsafe buildings. All such unsafe buildings are hereby declared to be public nuisances and shall be abated by repair, rehabilitation, demolition, or removal in accordance with the procedure specified in this chapter.

(Code of Iowa, Sec. 657A.1 and 364.12[3a])

145.03 UNSAFE BUILDING. “Unsafe building” means any structure or mobile home meeting any or all of the following criteria:

1. Various Inadequacies. Whenever the building or structure, or any portion thereof, because of:
 - A. Dilapidation, deterioration, or decay;
 - B. Faulty construction;
 - C. The removal, movement, or instability of any portion of the ground necessary for the purpose of supporting such building;
 - D. The deterioration, decay, or inadequacy of its foundation; or
 - E. Any other cause, is likely to partially or completely collapse.
2. Manifestly Unsafe. Whenever, for any reason, the building or structure, or any portion thereof, is manifestly unsafe for the purpose for which it is being used.
3. Inadequate Maintenance. Whenever a building or structure, used or intended to be used for dwelling purposes, because of dilapidation, decay, damage, faulty construction, or otherwise, is determined by any health officer to be unsanitary, unfit for human habitation or in such condition that it is likely to cause sickness or disease.
4. Fire Hazard. Whenever any building or structure, because of dilapidated condition, deterioration, damage, or other cause, is determined by the Fire Marshal or Fire Chief to be a fire hazard.
5. Abandoned. Whenever any portion of a building or structure remains on a site after the demolition or destruction of the building or structure or whenever any building or structure is abandoned for a period in excess of six months so as to constitute such building or portion thereof an attractive nuisance or hazard to the public.

145.04 NOTICE TO OWNER. The enforcement officer shall examine or cause to be examined every building or structure or portion thereof reported as dangerous or damaged and, if such is found to be an unsafe building as defined in this chapter, the enforcement officer shall give to the owner of such building or structure written notice stating the defects thereof. This notice may require the owner or person in charge of the building or premises, within 48 hours or such reasonable time as the circumstances require, to commence either the required repairs or improvements or demolition and removal of the building or structure or portions thereof, and all such work shall be completed within 90 days from date of notice, unless otherwise stipulated by the enforcement officer. If necessary, such notice shall also require the building, structure, or portion thereof to be vacated forthwith and not reoccupied until the required repairs and improvements are completed, inspected, and approved by the enforcement officer.

(Code of Iowa, Sec. 364.12[3h])

1. Notice Served. Such notice shall be served by sending by certified mail to the owner of record, according to Section 364.12[3h] of the *Code of Iowa*, if the owner is found within the City limits. If the owner is not found within the City limits, such service may be made upon the owner by registered mail or certified mail. The designated period within which said owner or person in charge is required to comply with the order of the enforcement officer shall begin as of the date the owner receives such notice.
2. Hearing. Such notice shall also advise the owner that he or she may request a hearing before the Council on the notice by filing a written request for hearing within the time provided in the notice.

145.05 CONDUCT OF HEARING. If requested, the Council shall conduct a hearing in accordance with the following:

1. Notice. The owner shall be served with written notice specifying the date, time and place of hearing.
2. Owner's Rights. At the hearing, the owner may appear and show cause why the alleged nuisance shall not be abated.
3. Determination. The Council shall make and record findings of fact and may issue such order as it deems appropriate.[†]

145.06 POSTING OF SIGNS. The enforcement officer shall cause to be posted at each entrance to such building a notice to read: "DO NOT ENTER. UNSAFE TO OCCUPY. CITY OF HEDRICK, IOWA." Such notice shall remain posted until the required demolition, removal or repairs are completed. Such notice shall not be removed without written permission of the enforcement officer and no person shall enter the building except for the purpose of making the required repairs or of demolishing the building.

145.07 RIGHT TO DEMOLISH; MUNICIPAL INFRACTION. In case the owner fails, neglects, or refuses to comply with the notice to repair, rehabilitate, or to demolish and remove the building or structure or portion thereof, the Council may order the owner of the building prosecuted as a violator of the provisions of this chapter and may order the enforcement officer to proceed with the work specified in such notice. A statement of the cost of such work shall

[†] **EDITOR'S NOTE:** Suggested forms of notice and of a resolution and order of the Council for the administration of this chapter are provided in the APPENDIX to this Code of Ordinances. Caution is urged in the use of this procedure. We recommend you review the situation with your attorney before initiating procedures and follow his or her recommendation carefully.

be transmitted to the Council. As an alternative to this action, the City may utilize the municipal infraction process to abate the nuisance.

(Code of Iowa, Sec. 364.12[3h])

145.08 COSTS. Costs incurred under Section 145.07 shall be paid out of the City treasury. Such costs shall be charged to the owner of the premises involved and levied as a special assessment against the land on which the building or structure is located, and shall be certified to the County Treasurer for collection in the manner provided for other taxes. In addition, the City may take any other action deemed appropriate to recover costs incurred.

(Code of Iowa, Sec. 364.12[3h])

[The next page is 1197]

CHAPTER 146

MANUFACTURED AND MOBILE HOMES

146.01 Definitions

146.03 Foundation Requirements

146.02 Conversion to Real Property

146.01 DEFINITIONS. For use in this chapter the following terms are defined:
(Code of Iowa, Sec. 435.1)

1. “Manufactured home” means a factory-built structure built under the authority of 42 U.S.C. Sec. 5403 which was constructed on or after June 15, 1976, and is required by federal law to display a seal from the United States Department of Housing and Urban Development.
2. “Manufactured home community” means any site, lot, field, or tract of land under common ownership upon which 10 or more occupied manufactured homes are harbored, either free of charge or for revenue purposes, and includes any building, structure, or enclosure used or intended for use as part of the equipment of the manufactured home community.
3. “Mobile home” means any vehicle without motive power used or so manufactured or constructed as to permit its being used as a conveyance upon the public streets and highways and so designed, constructed, or reconstructed as will permit the vehicle to be used as a place for human habitation by one or more persons; but also includes any such vehicle with motive power not registered as a motor vehicle in Iowa. A mobile home means any such vehicle built before June 15, 1976, which was not built to a mandatory building code and which contains no State or federal seals.
4. “Mobile home park” means any site, lot, field, or tract of land upon which three or more mobile homes or manufactured homes, or a combination of any of these homes, are placed on developed spaces and operated as a for-profit enterprise with water, sewer or septic, and electrical services available.

The term “manufactured home community” or “mobile home park” is not to be construed to include manufactured or mobile homes, buildings, tents, or other structures temporarily maintained by any individual, educational institution, or company on its own premises and used exclusively to house said entity’s own labor or students. The manufactured home community or mobile home park shall meet the requirements of any zoning regulations that are in effect.

146.02 CONVERSION TO REAL PROPERTY. A mobile home or manufactured home that is located outside a manufactured home community or mobile home park shall be converted to real estate by being placed on a permanent foundation and shall be assessed for real estate taxes except in the following cases:

(Code of Iowa, Sec. 435.26)

1. Retailer’s Stock. Mobile homes or manufactured homes on private property as part of a retailer’s or a manufacturer’s stock not used as a place for human habitation.
2. Existing Homes. A taxable mobile home or manufactured home that is located outside of a manufactured home community or mobile home park as of January 1, 1995,

shall be assessed and taxed as real estate, but is exempt from the permanent foundation requirement of this chapter until the home is relocated.

146.03 FOUNDATION REQUIREMENTS. A mobile home or manufactured home located outside of a manufactured home community or mobile home park shall be placed on a permanent frost-free foundation system that meets the support and anchorage requirements as recommended by the manufacturer or required by the *State Building Code*. The foundation system must be visually compatible with permanent foundation systems of surrounding residential structures. Any such home shall be installed in accordance with the requirements of the *State Building Code*.

(Code of Iowa, Sec. 103A.10 and 414.28)

[The next page is 1203]

CHAPTER 147

PROPERTY MAINTENANCE CODE

147.01 Adoption of Code

147.02 Additions, Deletions, and Changes

147.03 Repealer

147.04 Preservation of Rights

147.01 ADOPTION OF CODE. A certain document, a copy of which is on file in the office of the Clerk, being marked and designated as the *International Property Maintenance Code*, 2006 edition, as published by the International Code Council, be and is hereby adopted as the Property Maintenance Code of the City, for regulating and governing the conditions and maintenance of all property, buildings, and structures; by providing the standards for supplied utilities and facilities and other physical things and conditions essential to insure that structures are safe, sanitary, and fit for occupation and use; and the condemnation of buildings and structures unfit for human occupancy and use, and the demolition of such existing structures as provided herein; providing for the issuance of permits and collection of fees therefore, and each and all of the regulations, provisions, penalties, conditions, and terms of said Property Maintenance Code on file in the office of the Clerk are hereby referred to, adopted, and made part hereof, as if fully set out in this chapter, with the additions, insertions, deletions, and changes, if any, prescribed in Section 147.02 of this chapter. *(Ord. 4-2024 – May 24 Supp.)*

147.02 ADDITIONS, DELETIONS, AND CHANGES. The following sections are revised:

1. Section 101.1 - Insert: The City of Hedrick, Iowa
2. Section 103.5 - Insert: (fee schedule)
3. Section 302.4 - Insert: eight inches
4. Section 304.14 - Insert: May 1 to September 30
5. Section 602.3 - Insert: September 15 to June 15
6. Section 602.4 - Insert: September 15 to June 15

147.03 REPEALER. All ordinances or parts of ordinances in conflict herewith are hereby repealed.

147.04 PRESERVATION OF RIGHTS. Nothing in this chapter or in the *International Property Maintenance Code* hereby adopted shall be construed to affect any suit or proceeding impending in any court, or any rights acquired, or liability incurred, or any cause or causes of action acquired or existing under any act or ordinance hereby repealed as cited in Section 147.03 of this chapter, nor shall any just or legal right or remedy of any character be lost, impaired, or affected by this chapter.

o o o o o o o o o o

CHAPTER 148

RENTAL PERMIT PROCESS

148.01 Rental Permits

148.02 Fees Rates

148.01 RENTAL PERMITS.

1. Requirements for Rental Property. It shall be a violation of this Code for any person to let to another for rent and occupancy any dwelling, dwelling unit, duplex, multiple dwelling, rooming unit (except a rooming unit or units within owner-occupied single-family dwellings, condominiums, and cooperatives containing no more than two roomers) or rooming house unless: the owner or operator holds a valid Rental Permit, issued by the City Clerk, in the name of the owner or operator, applicable to those portions of the specific structure used for residential rental purposes.
2. Maintenance Inspections. Inspections of the provisions of the *International Property Maintenance Code*, 2006 edition shall be conducted upon request, on a complaint basis, and/or through a program of regular rental inspections which regular inspections shall be conducted as determined by resolution of the Council but shall not be conducted more frequently than yearly nor less frequently than as follows:
 - A. Multiple dwelling units: every two years;
 - B. Rooming houses: every two years;
 - C. Duplexes: every two years;
 - D. Single-family rental dwellings: every two years.
3. Rental Permit.
 - A. A Rental Permit shall be a document indicating compliance with the *International Property Maintenance Code*, 2006 edition and shall be valid for the fiscal year in which it is issued and is due on July 1st of each year. It shall become delinquent if not paid by August 1st of that year. Delinquent Rental Permits shall be charged a late fee of \$5.00 per month thereof it remains unpaid. The document shall be transferable from one owner or operator to another at the time prior to its expiration, termination, or revocation.
 - B. The owner or operator shall notify the City Clerk of any change of interest or ownership in the property within 30 days of any conveyance or transfer of interest affecting the property and provide the name and address of all persons who have acquired an interest herein.
 - C. In the event that the City Clerk has not been notified of such conveyance or transfer within the designated period of time, the Rental Permit shall be transferred from one owner or operator to another only upon payment of a \$35.00 fee which shall be assessed to the new owner or operator. The Rental Permit shall state the date of issuance, the address of the structure to which it is applicable, the name of the owner or operator to which it is applicable and its expiration date. All dwelling units and rooming units being

let for rent and occupancy without a valid permit or application for the same on file with the City Clerk and fees paid may be ordered vacated.

4. **Application For Rental Permit.** The owner or operator shall file, in duplicate, an application for Rental Permit with the City Clerk on application forms provided by the City and shall cause an inspection of all dwellings, dwelling units or rooming units listed on the application to be made within 60 days of the application.
5. **Issuance of a Rental Permit.** When all provisions of the *International Property Maintenance Code*, 2006 edition have been complied with by the owner or operator, the City Clerk shall issue a Rental Permit upon payment of all fees due, the amount of which shall be set by resolution of the Council.
6. **Extension of Rental Permit.** Rental Permits are valid through the expiration date contained thereon. However, extensions shall be granted to cover any time period between the stated expiration date and the period of time permitted by the property inspector to remedy any violation cited subsequent to a maintenance inspection, provided the rental application is on file with all fees paid.
7. **Revocation of a Rental Permit.**
 - A. The Council shall consider the revocation of a Rental Permit if petitioned by the property inspector for such revocation.
 - B. The owner or operator of the affected property shall be properly notified of the petition for revocation and shall be notified of the date, place and time of the Council's consideration of the petition and may appear to defend. The Council may revoke a Rental Permit upon finding of a violation of any provision of the *Internation Property Maintenance Code*, 2006 edition.
8. **Hearing When a Rental Permit Is Denied.** Any person whose application for a Certificate of Structure Compliance or Rental Permit has been denied, may request, and shall be granted a hearing on the matter before the Council under the procedures provided herein. Application for the appeal hearing must be made within 10 days of receipt of the written notice of denial.

148.02 FEES RATES.

1. **Rental Dwelling Operating Fee.** The annual fee for operating rental dwellings shall be:
 - A. Each dwelling unit, per unit \$45.00
 - B. Each efficiency unit, per unit \$45.00
 - C. Each rooming unit, per unit \$45.00
2. **Dwelling Inspection Fees.** The following inspection fees shall be charged for inspections made pursuant to the program of regular rental inspections and shall be set by resolution of the Council. Upon regular inspection, there shall be no charge for the initial inspection. If upon regular inspection, violations are noted and a notice of violation is served, the cost of the reinspection shall be charged to the property owner or operator for the reinspection and any subsequent reinspection caused by the violations.
3. **Penalty For Failure to Pay Fees.** Fees remaining unpaid for 30 days after due and delinquent shall constitute a lien upon the property or premises served and shall be

certified by the Clerk to the County Treasurer for collection in the same manner as property taxes.

(Chapter 148 – Ord. 5-2024 – May 24 Supp.)

[The next page is 1229]

CHAPTER 150

BUILDING NUMBERING

150.01 Definitions

150.03 Building Numbering Plan

150.02 Owner Requirements

150.01 DEFINITIONS. For use in this chapter, the following terms are defined:

1. “Owner” means the owner of the principal building.
2. “Principal building” means the main building on any lot or subdivision thereof.

150.02 OWNER REQUIREMENTS. Every owner shall comply with the following numbering requirements:

1. Obtain Building Number. The owner shall obtain the assigned number to the principal building from the Clerk.
(Code of Iowa, Sec. 364.12[3d])
2. Display Building Number. The owner shall place or cause to be installed and maintained on the principal building the assigned number in a conspicuous place to the street in figures not less than two and one half inches in height and of a contrasting color with their background.
(Code of Iowa, Sec. 364.12[3d])
3. Failure to Comply. If an owner refuses to number a building as herein provided, or fails to do so for a period of 30 days after being notified in writing by the City to do so, the City may proceed to place the assigned number on the principal building and assess the costs against the property for collection in the same manner as a property tax.
(Code of Iowa, Sec. 364.12[3h])

150.03 BUILDING NUMBERING PLAN. Building numbers shall be assigned in accordance with the building numbering plan on file in the office of the Clerk.

[The next page is 1235]

CHAPTER 151

TREES

151.01 Definition

151.02 Planting Restrictions

151.03 Duty To Trim Trees

151.04 Trimming Trees To Be Supervised

151.05 Disease Control

151.06 Inspection and Removal

151.01 DEFINITION. For use in this chapter, “parking” means that part of the street, avenue, or highway in the City not covered by sidewalk and lying between the lot line and the curb line or, on unpaved streets, that part of the street, avenue, or highway lying between the lot line and that portion of the street usually traveled by vehicular traffic.

151.02 PLANTING RESTRICTIONS. No tree shall be planted in any parking or street except in accordance with the following:

1. Alignment. All trees planted in any street shall be planted in the parking midway between the outer line of the sidewalk and the curb. In the event a curb line is not established, trees shall be planted on a line 10 feet from the property line.
2. Spacing. Trees shall not be planted on any parking that is less than nine feet in width, or contains less than 81 square feet of exposed soil surface per tree. Trees shall not be planted closer than 20 feet from street intersections (property lines extended) and 10 feet from driveways. If it is at all possible, trees should be planted inside the property lines and not between the sidewalk and the curb.
3. Prohibited Trees. No person shall plant in any street any fruit-bearing tree or any tree of the kinds commonly known as cottonwood, poplar, box elder, Chinese elm, evergreen, willow, or black walnut.

151.03 DUTY TO TRIM TREES. The owner or agent of the abutting property shall keep the trees on, or overhanging the street, trimmed so that all branches will be at least 15 feet above the surface of the street and eight feet above the sidewalks. If the abutting property owner fails to trim the trees, the City may serve notice on the abutting property owner requiring that such action be taken within five days. If such action is not taken within that time, the City may perform the required action and assess the costs against the abutting property for collection in the same manner as a property tax.

(Code of Iowa, Sec. 364.12[2c and e])

151.04 TRIMMING TREES TO BE SUPERVISED. Except as allowed in Section 151.03, it is unlawful for any person to trim or cut any tree in a street or public place unless the work is done under the supervision of the City.

151.05 DISEASE CONTROL. Any dead, diseased, or damaged tree or shrub that may harbor serious insect or disease pests or disease injurious to other trees is hereby declared to be a nuisance.

151.06 INSPECTION AND REMOVAL. The Council shall inspect or cause to be inspected any trees or shrubs in the City reported or suspected to be dead, diseased or damaged, and such trees and shrubs shall be subject to the following:

1. City Property. If it is determined that any such condition exists on any public property, including the strip between the curb and the lot line of private property, the Council may cause such condition to be corrected by treatment or removal. The Council may also order the removal of any trees on the streets of the City which interfere with the making of improvements or with travel thereon.

2. Private Property. If it is determined with reasonable certainty that any such condition exists on private property and that danger to other trees or to adjoining property or passing motorists or pedestrians is imminent, the Council shall notify by certified mail the owner, occupant or person in charge of such property to correct such condition by treatment or removal within 14 days of said notification. If such owner, occupant, or person in charge of said property fails to comply within 14 days of receipt of notice, the Council may cause the condition to be corrected and the cost assessed against the property.

(Code of Iowa, Sec. 364.12[3b and h])

[The next page is 1349]

ZONING AND SUBDIVISION

TABLE OF CONTENTS

CHAPTER 165 - ZONING REGULATIONS	1349
--	------

CHAPTER 165

ZONING REGULATIONS

165.01 Title	165.20 Essential Services
165.02 Purpose	165.21 Validity of Existing Building Permits
165.03 Definitions	165.22 Agricultural Districts A-1
165.04 Establishment of Districts	165.23 Residence Districts R-1
165.05 Official Zoning Map	165.24 General Business Districts B-1
165.06 Annexed Areas	165.25 Industrial Districts I-1
165.07 Zoning Affects Every Structure and Use	165.26 Mobile Home Parks
165.08 Continuing Existing Uses	165.27 Signs
165.09 Non-Conforming Uses	165.28 Off-Street Parking Areas and Loading Spaces
165.10 Street Frontage, Minimum Requirements	165.29 Designated Flood Hazard Area
165.11 Lot Area Requirements	165.30 Garages; Motor Fuel Stations; and Car Washes
165.12 Numbers of Uses On One Lot	165.31 Trailers; Recreational Vehicles and Tents
165.13 Accessory Buildings in Residence Districts	165.32 Hotels and Motels
165.14 Adjoining Lots Under One Ownership	165.33 Additional Requirements, Exceptions, and Modifications
165.15 Required Yard Cannot be Reduced or Used by Another Building	165.34 Zoning Administration
165.16 Conversion of Dwelling	165.35 Board of Adjustment
165.17 Transitional Uses in R Districts	165.36 District Changes and Zoning Code Amendments
165.18 Minimum Ground Floor Area for Dwellings	165.37 Penalty
165.19 Obstructions to Vision at Street Intersections Prohibited	

165.01 TITLE. This chapter, including the Official Zoning Map, shall be known as, and may be cited and referred to as, the City of Hedrick Zoning Code.

165.02 PURPOSE. The purpose of this Zoning Code is to provide adequate light and air, to prevent overcrowding of land, to avoid undue concentration of population, to regulate the use of land, and to promote the health, morals, safety, and general welfare in the City.

165.03 DEFINITIONS. For purposes of this chapter the following terms are defined:

1. Words beginning with “A.”
 - A. “Abandonment” means to cease or discontinue a use of activity without intent to resume, as distinguished from short term interruptions such as during periods of remodeling, maintenance, or normal periods of vacation or seasonal closure.
 - B. “Accessory use” or “Structure” means a use or a structure subordinate to the principal building on the same lot and serving a purpose customarily incidental there to.
 - C. “Addition” means any construction which increases the size of a building or structure in terms of site coverage, height, length, width, or gross floor area.
 - D. “Alley” means a public way, other than a street, affording secondary means of access to abutting property.
 - E. “Alteration” means any construction or physical change in the internal arrangement of spaces, the supporting members, the positioning on a site, or the appearances of a building or structure.

- F. “Attached” means having one or more walls in common with a principal building or connected to a principal building by an integral architectural element, such as a covered passageway, façade wall extension, or archway.
- G. “Automobile repair, major” means general repair, rebuilding, or reconditioning of engines, motor vehicles or trailers; collision service, including body, frame, or fender straightening or repair; overall painting or paint shop; vehicle steam cleaning.
- H. “Automobile repair, minor” means minor repairs, incidental body and fender work, painting and upholstering, replacement of parts and motor service to passenger automobiles and trucks not exceeding one- and one-half tons capacity, but not including any operation specified under automobile repair, major.
2. Words beginning with “B.”
- A. “Basement” means a story having part but not more than 50 percent of its height below the average grade of the adjoining ground (as distinguished from a “cellar”). A basement shall be counted as a story for the purpose of height measurement.
- B. “Bed and breakfast inn” means a house, or portion thereof, where short-term lodging rooms and meals are provided for compensation. The operator of the inn shall live on the premises or in adjacent premises.
- C. “Billboard” means a large outdoor board for displaying advertisements.
- D. “Block, front” means a portion of a street on a particular side of the street without a separation by a cross- street or alley.
- E. “Board” means the Board of Adjustment, established by the City pursuant to Chapter 414 of the *Code of Iowa*, expressly for the purpose of granting relief from situations of hardship, to hear appeals, and to provide for approval of variances and conditional, uses as provided within this Code.
- F. “Boarding house” means an establishment with lodging for three or more persons where meals are regularly prepared and served for compensation and where food is placed upon the table family-style, without service or ordering of individual portions from a menu.
- G. “Building” means any structure for the shelter or enclosure of persons, animals, or chattels.
3. Words beginning with “C.”
- A. “Cellar” means a story having 50 percent or more of its height below the average grade of the adjoining ground. A cellar shall be counted as a story, for purposes of height measurement, only if used for dwelling purposes other than by a janitor or caretaker employed on the premises.
- B. “Change of use” means the replacement of an existing use by a new use.
- C. “Comprehensive Plan” means the duly adopted Comprehensive Plan of the City.

- D. “Conditional use” means a use that may be permitted in a zoning district subject to special conditions and with the approval of the Board of Adjustment. Conditional uses are considered identical to special exception uses as authorized by the *Code of Iowa*.
- E. “Corner lot” means a lot located at the junction of at least two streets, private ways, or courts or at least two segments of a curved street, private way, or court, at which the angle of intersection is no greater than 135 degrees.
4. Words beginning with “D.”
- A. “Detached” means fully separated from any other building or jointed to another building in such a manner as not to constitute an enclosed or covered connection.
- B. “District” means any section of the City within which the zoning regulations are uniform.
- C. “Drive-in facility” means an establishment that, by design of physical facilities or by service or packaging procedures, encourages or permits customers to receive a service or obtain a product that may be used or consumed in a motor vehicle on the premises or to be entertained while remaining in an automobile.
- D. “Dwelling” means a building or portion thereof occupied or intended to be occupied exclusively for residence purposes but not including a tent, cabin, trailer, or a room in a hotel or motel.
- E. “Dwelling group” means two or more detached dwellings located on a parcel of land in one ownership.
- F. “Dwelling, single-family, attached” means one of two or more residential buildings having a common party wall separating dwelling units.
- G. “Dwelling, single-family, detached” means a residential building containing not more than one dwelling entirely surrounded by open space on the same lot.
- H. “Dwelling, two-family” means a building or portion thereof used for occupancy by two families living independently of each other and containing two dwelling units.
- I. “Dwelling, multi-family” means a building or portion thereof used for occupancy by three or more families living independently of each other and containing three or more dwelling units.
5. Words beginning with “E.”
- A. “Easement” means a privilege or right of use granted on, above, under, or across a particular tract of land for a specific purpose by one owner to another, public or private agency or utility.
- B. “Enclosed” means a roofed or covered space fully surrounded by walls.
- C. “Essential services” means the erection, construction, alteration, or maintenance, by public utilities or municipal or other governmental agencies, of underground or overhead gas, electrical, steam, or water transmission or distribution systems, collection, communication, supply, or disposal systems, including poles, wires, mains, drains, sewers, pipes, conduits, cables, fire alarm

- boxes, police call boxes, traffic signals, hydrants, and other similar equipment and accessories in connection therewith; reasonably necessary for the furnishing of adequate service by such public utilities or municipal or other governmental agencies or for the public health or safety or general welfare, but not including buildings.
6. Words beginning with “F.”
 - A. “Family” means one or more persons related by blood, marriage, or adoption, together or with their domestic servants, maintaining a common household in a dwelling.
 7. Words beginning with “G.”
 - A. “Garage, private” means a detached accessory building or portion of a principal building used for the storage of self-propelled passenger vehicles or trailers of the occupants of the premises or not more than one truck of a rated capacity not exceeding one and one-half tons.
 - B. “Garage, public” means any building where automotive vehicles are painted, repaired, rebuilt, reconstructed, and or stored for compensation.
 - C. “Garage, storage” means any building or premises used for housing only of motor driven vehicles pursuant to previous arrangements and not to transients, and, at which, automobile fuels and oils are not sold, and motor driven vehicles are not being equipped, repaired, hired, or sold.
 8. Words beginning with “H.”
 - A. “Height” means in the case of a wall, or part of a building, the vertical distance from the average established curb grade in front of the lot or from the average finished grade at the building line, if higher, to the average height of the top of the cornice of a flat roof, or roof line, or to the deck line of a mansard roof, or to the middle height of the highest gable or dormer in a pitched or hipped roof, or if there are no gables or dormers, to the middle height of such pitched or hipped roof.
 - B. “Highway” or “Primary thoroughfare” means an officially designated federal or State numbered highway or other road designated as a highway or primary thoroughfare on the Transportation Plan as officially adopted and amended from time to time by the Planning and Zoning Commission and Council.
 - C. “Home occupation” means an occupation, profession, activity, or use that is clearly a customary, incidental, and secondary use of a residential dwelling unit which does not alter the exterior of the property or affect the residential character of the neighborhood.
 - D. “Hotel” means a facility offering transient lodging accommodations on a daily rate to the general public and providing additional services, such as restaurants, meeting rooms, and recreational facilities.
 9. Words beginning with “I.”
 10. Words beginning with “J.”
 11. Words beginning with “K.”

12. Words beginning with “L.”
- A. “Land use plan” means the comprehensive long-range plan for the desirable use of land in the community, as officially adopted and as amended from time to time by the Planning and Zoning Commission and Council; the purpose of such plan being, among other things, to serve as a guide to the zoning and progressive changes in the zoning of land to meet changing community needs, in the subdividing and use of undeveloped land, and in the acquisition of land for such public purposes as streets, parks, schools, and other public buildings or public uses.
- B. “Lodging house” means a building where, for compensation, lodging is provided for three or more persons.
- C. “Lot area” means the horizontal area within the lot lines of the lot.
- D. “Lot corner” means a lot of which at least two adjacent sides abut for their full lengths upon a street, provided that the interior angle at the intersection of such two sides is less than 135 degrees.
- E. “Lot depth” means the mean horizontal distance between the front and rear lot lines.
- F. “Lot lines” means lines bounding a lot, as defined herein.
- G. “Lot of record” means a lot which is a part of a subdivision, the map of which has been recorded in the office of the County Recorder; or a parcel of land, the deed to which has been recorded in the office of the County Recorder prior to the adoption of these regulations.
- H. “Lot width” means the mean horizontal distance across the lot between side lot lines at the building line measured at right angles to the depth.
- I. “Lot” means a parcel of land, abutting on a street, whose area, in addition to the parts thereof occupied or hereafter to be occupied by a building and its accessory buildings, is sufficient to provide the yards and courts required by the ordinance.
13. Words beginning with “M.”
- A. “Manufactured home” means a factory-built structure built under the authority of 42 United States Code Section 5403 is required by federal law to display a seal from the United States Department of Housing and Urban Development, and was constructed on or after June 15, 1976, to be used as a place for human habitation. If a manufactured home is placed in a mobile home park, the home must be titled and is subject to the mobile home square foot tax. If a manufactured home is placed outside a mobile home park, the home is to be assessed and taxed as real estate, a mobile home is not a modular or manufactured home.
- B. “Mobile home park” means any site, lot, field, or tract of land under common ownership upon which two or more occupied mobile homes, manufactured homes, modular homes, or a combination of the homes are harbored, either free of charge or for revenue purposes, and shall include any building, structure, tent, vehicle, or enclosure used or intended for use as part of the equipment of such mobile home park. The term mobile home park shall not be construed to include mobile homes, buildings, tents, or other structures

temporarily maintained by any individual, educational institution, or company on their own premises and used exclusively to house their own labor or students. A mobile home park must be classified as to whether it is a residential mobile home park or a recreational mobile home park or both. The Mobile Home Park Residential Landlord Tenant Act only applies to residential mobile home parks.

C. “Mobile home” means any vehicle without motive power used or so manufactured or constructed as to permit its being used as a conveyance upon the public streets and highways and so designed, constructed, or reconstructed as will permit the vehicle to be used as a place for human habitation by one or more persons; but shall also include any such vehicle with motive power not registered as a motor vehicle in the State. A mobile home is not built to a mandatory Building Code, contains no State or federal seals, and was built before June 15, 1976. If mobile home is place outside a mobile home park, the home is to be assessed and taxed as real estate. A mobile home is not a manufactured or modular home as that term is defined in this Code.

D. “Modular home” means a factory-built structure built on a permanent chassis which is manufactured to be used as a place of human habitation, is constructed to comply with the *State Building Code* for modular factory-built structures, and must display the seal issued by the State Building Code Commissioner. If a modular home is placed in a mobile home park, the home is subject to the annual tax as required by Section 435.22 of the *Code of Iowa*. If a modular home is placed outside a mobile home park, the home shall be considered real property and is to be assessed and taxed as real estate.

E. “Motel” means a building or group of buildings containing apartments or rooming units, each of which maintains a separate entrance. Such building or group of buildings is designed, intended, or used primarily for the accommodation of automobile travelers and provides automobile parking conveniently located on the premises.

F. “Motor fuel station” means a place where minor automobile repair is conducted and where gasoline, diesel oil, kerosene, or any other motor fuel or lubricating oil or grease for operating motor vehicles is offered for sale to the public and deliveries are made directly into motor vehicles, including greasing and oiling and the sale of automobile accessories on the premises.

14. Words beginning with “N.”

A. “Non-conforming use” means a building, structure, or premises lawfully occupied at the time of the enactment of the ordinance by a use that does not conform with the provisions of the ordinance for the district in which it is located; also such use resulting from changes in zoning districts or in textual provisions made hereafter.

15. Words beginning with “O.”

16. Words beginning with “P.”

A. “Parking area, accessory” means an area of one or more parking spaces located on the same property as the building, structure, or premises it is intended to serve, or on adjoining or nearby property other than the public right-

of-way, and of such shape and nature as to be appropriate and usable for the parking or storage, loading and unloading of self-propelled vehicles.

B. “Permanent foundation” means a foundation that consists of load-bearing support walls, constructed of concrete, that are buried at least 42 inches deep. This permanent foundation shall be in the form of a solid wall located under the exterior walls of the structure, or a pier that supports the alternative structure construction of manufactured homes, as to support and secure the structure. In all installations, the mobilehome, manufactured home, or modular home shall be attached to the permanent foundation in such a manner as to prevent lateral movement, settling, or heaving. The permanent foundation system must be visually compatible with the aesthetics of surrounding residential structures.

C. “Planning and Zoning Commission” means The Planning And Zoning Commission of the City, as authorized by Chapter 23 of this Code of Ordinances.

D. “Principal use” means the main use of land or structures as distinguished from secondary or accessory use. For example, a house is a principal use in a residential area; a garage or pool is an accessory use.

17. Words beginning with “Q.”

18. Words beginning with “R.”

A. “Recreational vehicle” means a vehicle towed or self-propelled on its own chassis or attached to the chassis of another vehicle and designed or used for temporary dwelling, recreational, or sporting purposes. Recreational vehicles include, but are not limited to, travel trailers; campers; motor coach homes; converted buses and trucks; boats and boat trailers.

19. Words beginning with “S.”

A. “Sign” means any structure or device for visual communication that is used for the purpose of bringing the subject thereof to the attention of the public, but not including any flag, badge, or insignia of any government or governmental agency.

B. “Sign, gross surface area of story” means the entire area within a single continuous perimeter enclosing the extreme limits of such sign and in no case passing through or between any adjacent elements lying outside the limits of such signs and not forming an integral part of the display.

(1) That portion of a building included between the upper surface of any floor and the upper surface of the floor next above, or the ceiling or roof next above such floor; provided that, for the purpose of determining the required dimensions of yards and courts, then the average story height of a building exceeds 12 feet, each 12 feet or fraction thereof of the total building height shall be considered a separate full story or fractional story respectively, except the first story which may be 15 feet high.

C. “Story, half” means a partial story under a gable, hip, or gambrel roof, the wall plates of which on at least two opposite exterior walls are not more than four feet above the floor of such story; provided, however, that any partial

story used for residence purposes, other than for a janitor or caretaker and their family, shall be deemed a full story.

D. “Street” means any public way set aside as a permanent right-of-way for vehicular or pedestrian access 21 feet or more in width if it existed at the time of the enactment of the ordinance; and any such public way created after enactment of the ordinance, provided it is 60 feet or more in width.

E. “Structural alteration” means any change in the supporting members of a building including, but not limited to, bearing walls, load-bearing partitions, columns, beams, or girders, or any substantial change in the roof or in the exterior walls.

F. “Structure” means anything constructed, the use of which requires permanent location on the ground, or attached to something having permanent location on the ground.

20. Words beginning with “T.”
21. Words beginning with “U.”
22. Words beginning with “V.”
23. Words beginning with “W.”
24. Words beginning with “X.”
25. Words beginning with “Y.”

A. “Yard, front” means an open space extending the full width of the lot between a building and the front lot line, unoccupied and unobstructed from the ground upward, except as hereinafter specified. A corner lot shall have two front yards.

(1) “Front yard, least depth” means the shortest distance, measured horizontally, between any part of a building, other than such parts as hereinafter excepted, and the front lot line.

B. “Yard, rear” means an open space extending the full width of a lot between a building and the rear lot line, unoccupied and unobstructed from the ground upward, except as hereinafter specified.

(1) “Rear yard, least depth” means the shortest distance, measured horizontally, between any part of a building, other than such parts as hereinafter excepted, and the rear lot line. In the case of an irregular, triangular, or gore-shaped lot, a line 10 feet in length entirely within the lot, parallel to and maximum distance from the front lot line, shall be considered the rear lot line.

C. “Yard, side” means an open space extending from the front yard to the rear yard between a building and the side lot line, unoccupied and unobstructed from the ground upward, except as hereinafter specified.

(1) “Side yard, least width” means the shortest distance, measured horizontally, between any part of a building, other than such parts as hereinafter excepted, and the nearest side lot line.

26. Words beginning with “Z.”

165.04 ESTABLISHMENT OF DISTRICTS. For the purpose of this chapter, the following districts are designated:

1. Agricultural Districts A-1
2. Residence District R-1
3. Business Districts B-1
4. Industrial Districts I-1
5. Mobile Home Park Districts

165.05 OFFICIAL ZONING MAP. As shown by the Official Zoning Map, the City is divided into five classes of districts. The boundaries of these districts are hereby established as shown on the Official Zoning Map of the City, and said map and all notations, references and other information shown thereon shall be and are hereby made a part of this chapter by reference. The Official Zoning Map, signed by the Mayor and properly attested by signature of the Clerk and date of adoption, shall be and remain on file in the office of the Clerk.

1. Boundaries. The boundaries of these districts are hereby established as shown on a map entitled "Zoning Map," which accompanies and is hereby made a part of this chapter. The district boundary lines on said map are intended to follow lot lines, and centerlines of streets or alleys, the centerlines of streets or alleys projected, railroad right-of-ways, or the corporate limit lines, all as they existed at the time of enactment of the chapter; but where a district boundary line does not clearly coincide with lot lines, it shall be determined by scaling.
2. Divided Lots. Where a district boundary line divides a lot which was in single ownership and of record at the time of enactment of the chapter, the rules applying to the less restricted portion of such lot shall be considered as extending to the entire lot. If the more restricted portion of such lot is more than 50 feet beyond said dividing district boundary line, such less restricted use shall be limited to the portion of the lot lying within 50 feet of said boundary line.
3. Interpretations. Questions concerning the exact location of district boundary lines shall be determined by the Board of Adjustment according to rules and regulations which it may adopt, as hereinafter provided under Section 165.35.
4. Official Zoning Map.

EDITOR'S NOTE			
<p>The City's current zoning Map is located at City Hall. Since the adoption of the Official Zoning Map, as noted above, each ordinance listed below with the date of adoption by the City, following a recommendation by the Planning and Zoning Commission, has modified the Official Zoning Map. Each of these ordinances modifying the Official Zoning Map is now saved from repeal and is in full force and effect.</p>			
ORDINANCE	ADOPTED	ORDINANCE	ADOPTED
6-5-2006			
30-4-307			
3-2006	June 5, 2006		
1-2015	January 28, 2015		

[The next page is 1363]

165.06 ANNEXED AREAS. All territory which may hereafter be annexed to the community shall be classed automatically as being in Agricultural District A-1 until such classification shall have been changed by amendment of the chapter as provided hereinafter.

165.07 ZONING AFFECTS EVERY STRUCTURE AND USE. Except as hereinafter provided, no building, structure, or land shall hereafter be used and no building or part thereof or structure shall be erected, constructed, reconstructed, occupied, moved, altered, or repaired, except in conformity with the regulation herein specified for the class of district in which it is located.

165.08 CONTINUING EXISTING USES. Any building, structure, or use lawfully existing at the time of enactment of the Zoning Code may be continued, except certain non-conforming uses as provided under non-conforming uses in Section 165.09. Nothing in the zoning code shall prevent the strengthening or restoring to a safe condition any part of any building or structure declared unsafe by any competent authority.

165.09 NON-CONFORMING USES. Except as hereinafter provided under the designated exceptions below.

1. **Damaged Structures.** Any non-conforming building or structure which has been or may be damaged by fire, flood, explosion, earthquake, war, riot, or an act of God, may be reconstructed and used as before if it be done within 12 months of such calamity, unless damaged more than 50 percent of its fair market value, as determined by the Board of Adjustment, at the time of such damage, in which case reconstruction shall be in accordance with the provision of the Zoning Code.
2. **Discontinued Use or Changed Use.** The following shall not be devoted again to non-conforming use: buildings, structures, or premises where a non-conforming use has been or may be discontinued for more than one year; buildings, structures, or premises that have been changed or may be changed to a use permitted in the district in which they are located.
3. **Conformity Period.** Any building or structure devoted to a non-conforming use of with a fair market value of less than \$500.00, as determined by the Board of Adjustment, may be continued for a period not to exceed three years after enactment of the Zoning Code, whereupon such non-conforming use shall cease and thereafter such building or structure shall be removed or changed to a conforming use.
4. **Exceptions.** The foregoing provision under the non-conforming uses Subsections 1, 2, 3, and 4 under Section 165.09, insofar as these limit reconstructions or require certain uses to cease or buildings or structures to be removed or changed, shall not be applicable where any such building, structure, or use would be conforming under the Comprehensive or Land Use Plan as defined herein.

165.10 STREET FRONTAGE, MINIMUM REQUIREMENTS. No lot created after the adoption of the Zoning Code shall contain any building used as a dwelling unless it abuts at least 37.5 feet on a street or has a permanent exclusive non-obstructed easement of access not less than 37.5 feet wide to a street.

165.11 LOT AREA REQUIREMENTS.

1. Existing Lots of Record. In any district where dwellings are permitted, a one-family detached dwelling may be constructed on any size lot officially recorded at the time of enactment of the zoning code, provided that:
 - A. The owner does not own any adjoining property; and
 - B. The proposed yard spaces satisfy requirements stipulated for the district in which said lot is located.

Requirements may be modified by the Board of Adjustment as set forth hereinafter.

2. Lots Unserved by Sewer or Water. In any district where neither water supply nor public sanitary sewer is accessible, the otherwise specified lot area shall be a minimum 20,000 square feet with width requirements of 100 feet. If, however, public water and sewer supply systems are accessible and will be installed, these requirements shall be 10,000 square feet and 75 feet, respectively. The City Engineer or their equivalent shall certify that said areas will be large enough to satisfy all applicable requirements concerning water supply and the disposal of sanitary wastes.

165.12 NUMBERS OF USES ON ONE LOT. No lot shall contain more than one principal use.

165.13 ACCESSORY BUILDINGS IN RESIDENCE DISTRICTS.

1. Size of Structure. No accessory building shall be erected in any yard other than a rear yard and it shall occupy less than 30 percent of a required rear yard. Accessory buildings shall be limited to 15 feet in height and shall be distant at least four feet from all lot lines adjoining lots which are in any R District, and at least six feet from alley lines and four feet from any other buildings or structures on the same lot.
2. Topography. Where the natural grade of a lot at the front wall of the principal building is more than eight feet above the average established curb grade in front of the lot, a private garage may be erected within any yard or court, but not within 10 feet of any property line, provided that at least one-half of the height of such private garage shall be below the level of the yard or court.
3. Attached Garage or Carport. A garage or carport attached directly to the dwelling or connected by a breezeway or similar structure shall become a part of the principal building and shall comply with all yard requirements of the dwelling.

165.14 ADJOINING LOTS UNDER ONE OWNERSHIP. Where two adjoining lots are under one ownership, an accessory building may be constructed on one lot if the adjacent lot contains the principal structure. If the lot containing the accessory structure is sold independently of the lot containing the principal structure, there is a designated conformity period of one year for that lot to have a principal structure built or the accessory structure removed from the non-conforming lot. The accessory structure must comply with the regulations contained in this Zoning Code regarding size and location on the lot.

165.15 REQUIRED YARD CANNOT BE REDUCED OR USED BY ANOTHER BUILDING.

1. Area. No lot, yard, court, parking area, or other open space shall be so reduced in area or dimension as to make any such area or dimension less than the minimum required by the Zoning Code. If already less than the minimum required, it shall not be

further reduced. Each building or structure shall have its own open space as required in this Zoning Code and such open space shall not be included as part of the open space to any other building or structure.

2. Garages and Parking. The space used for a private garage and parking area shall be considered as part of the open space required about a principal building and the same rules shall apply as to size. Such space shall not be reduced or included as part of any required open space for another building or structure.

165.16 CONVERSION OF DWELLING. The conversion of any building or dwelling, or the conversion of any dwelling so as to accommodate an increased number of dwelling units or families, shall be permitted only within a district in which a new building for similar occupancy would be permitted under the Zoning Code. Such conversion will be permitted only when the resulting occupancy will comply with the requirements governing new construction in such district with respect to: lot size, lot area per dwelling unit, dimensions of yards, and other open spaces, and off-street parking. Each conversion shall be subject also to further requirements as may be specified hereinafter within the section applying to each district.

165.17 TRANSITIONAL USES IN R DISTRICTS. In any R-1 District a transitional use shall be permitted on a lot the side lot line of which adjoins, either directly or across an alley, any B or I Districts. The permitted transitional uses for any such lot in an R-1 District shall be any use permitted in the B-1 District. In the case of any such lot in an R-1 District, the requirements governing lot area per dwelling unit, off-street parking, yards, and other open spaces shall be the same as for the district respectively next listed in Section 165.04. Any transitional use authorized under this section shall not extend more than 100 feet from the side lot line of the lot abutting on the zoning district boundary line.

165.18 MINIMUM GROUND FLOOR AREA FOR DWELLINGS.

1. One-Story Dwellings. A one-story dwelling shall contain not less than 720 square feet of usable ground floor area, exclusive of open porches, garages, or steps.
2. Multi-Story Dwellings. A one and one-half or two-story dwelling shall contain not less than 600 square feet of ground floor area, exclusive of open porches, garages, or steps.

165.19 OBSTRUCTIONS TO VISION AT STREET INTERSECTIONS PROHIBITED. On a corner lot, there shall be provided an unobstructed view across a triangle formed by joining points measured 20 feet along the property line from the intersection of two streets or 15 feet along both the street and alley line from the intersection of street and alley. Within the triangle there shall be no sight-obstructing or partly obscuring wall, fence, or foliage higher than 30 inches above grade or in the case of trees, foliage lower than five feet. Vertical measurement shall be made at the top of the curb on the street or alley adjacent to the nearest side of the triangle or if no curb exists, from the edge of the nearest traveled way.

165.20 ESSENTIAL SERVICES. Essential services shall be permitted as authorized and regulated by law and other ordinances of the community, it being the intention hereof to exempt such essential services from the application of the Zoning Code.

165.21 VALIDITY OF EXISTING BUILDING PERMITS. Nothing herein contained shall require any change in the over-all layout, plans, construction, size, or designated use of any development, building, structure, or part thereof, for which official approvals and required building permits have been granted before the enactment of the Zoning Code. Such

construction, conforming with approved plans, shall have been started prior to the effective date of the Zoning Code and completion thereof carried on in a normal manner within the subsequent six-month period and not discontinued until completion, except for reasons beyond the builder's control.

165.22 AGRICULTURAL DISTRICTS A-1. The following are provisions of the A-1 Agricultural District:

1. Permitted Principal Uses.
 - A. Agricultural activities such as crop farming and truck gardening, but not including livestock farming, general grazing and pasturing, confinement feeding, or other concentrated feed lot activities.
 - B. Public parks, playgrounds, and recreational areas.
 - C. Essential services and municipal administrative or public service buildings or properties, except such uses as storage yards, warehouses, public garages, or other uses customarily conducted as gainful business, provided any building is located not less than 20 feet from any lot in any R District.
 - D. Cemeteries of 10 acres or more in size.
 - E. Churches, chapels, or parish houses located not less than 20 feet from any side lot line in any R District.
 - F. Any building or structure occupied or used for preschool, elementary, junior high, or high schools, public libraries, and similar public cultural uses located not less than 20 feet from any side lot line.
 - G. Sale of nursery and greenhouse products.
 - H. Railroad right-of-way and tracks, not including switching, storage terminal facilities, or freight yards.
 - I. Non-farm, single-family detached dwellings on lots of two acres or more.
 - J. Transformer stations and booster or pressure regulating stations without service yard or storage.
 - K. A mobile home, manufactured home, or modular home only if it is installed upon a permanent foundation as defined herein.
2. Conditional Uses.
 - A. Privately operated country clubs, golf courses, swimming clubs, riding stables, and similar recreation uses provided that any principal accessory building in connection therewith shall be located not less than 200 feet from any lot in an R District.
 - B. Agricultural activities including livestock farming, general grazing and pasturing, confinement feeding or other concentrated feedlot activities when at least 1,320 feet from an R or B District.
3. Permitted Accessory Uses.
 - A. Buildings, structures, and uses accessory to agricultural uses including roadside stands, selling produce grown on the premises, provided such roadside stands are located not less than 20 feet from a street or highway right-of-way line.
 - B. Private garages or parking areas.
 - C. Living quarters of persons employed on the premises.

D. Customary incidental home occupations such as handicraft, dressmaking, millinery, and preserving, or similar activity carried on solely by resident occupants within their residence subject to the following provisions:

- (1) No more than one room shall be used for such purposes by any resident family;
- (2) No such use shall require internal or external alterations or involve construction features or the use of mechanical equipment not customarily in dwellings;
- (3) Nothing is sold or offered for sale that has not been produced on the premises;
- (4) No display of goods or services pertaining to such shall be visible from the street or road.

E. Signs as regulated by Section 165.27.

4. Height Regulations. No principal structure shall exceed two and one-half stories or 35 feet in height from the average established curb grade in front of the lot or average finished grade at the building line; if higher, and no accessory structure shall exceed 15 feet in height, except as provided in Section 165.33.

5. Lot Area, Frontage and Yard Requirements. The following minimum requirements shall be observed subject to the additional requirements, exceptions, and modifications in Section 165.33. Each lot shall contain a minimum area of two acres.

1. Maximum Height of Principal Structure	1. Minimum Lot Width	1. Minimum Front Yard Depth	1. Minimum Side Yard Width	1. Minimum Rear Yard Depth
2. 1 to 2 ½ Stories	2. 200 feet	2. Along State and federal roads 80 feet 3. Other public roads 60 feet	2. 30 feet	2. 100 feet

Accessory buildings must be at least four feet from the lot lines.

[The next page is 1373]

165.23 RESIDENCE DISTRICTS R-1. The following are provisions of the Residence Districts R-1:

1. Permitted Principal Uses.
 - A. One-family detached dwellings.
 - B. Public parks, playgrounds, and recreational areas.
 - C. Essential services as defined herein and municipal administrative or public buildings or properties, except such uses as storage yards, warehouses, garages, or other uses customarily conducted as gainful business, provided any building is located not less than 20 feet from any lot in any R District.
 - D. Cemeteries of 10 acres or more in size.
 - E. Churches, chapels, or parish houses located not less than 20 feet from any side lot line in any R District.
 - F. Any building or structure occupied or used for preschool, elementary, junior high or high schools, and public libraries located not less than 20 feet from any side lot line.
 - G. Transformer stations and booster or pressure regulating stations, without service yard or storage.
 - H. A mobile home, manufactured home, or modular home only if it is installed upon a permanent foundation as defined herein.
2. Conditional Uses.
 - A. Privately operated, country clubs, golf courses, swimming clubs, riding stables, and similar recreation uses provided that any principal or accessory building in connection therewith shall be located not less than 200 feet from any lot in an R District.
 - B. Dwelling Groups.
 - C. Parking areas accessory to a use in an adjoining less restricted district, when abutting or directly across an alley, subject to the applicable conditions stipulated in Section 165.35, and such further conditions as may be stipulated by the Board of Adjustment.
 - D. Hospitals, sanitariums, and nursing homes provided that any such buildings shall be at least 50 feet from any lot in any R District. Hospitals shall be located on lots of five acres or more, sanitariums on lots of 10 acres or more and nursing homes on lots of 20,000 square feet or more.
 - E. Residence development project exempt from district height regulations see Section 165.33(2).
 - F. Office of civic, religious, or charitable organizations and financial or insurance institutions conducting their activities primarily by mail and not handling merchandise or rendering services on the premises.
 - G. Physicians' and dentists' offices and private clinics for human care, professional offices of architects, engineers, lawyers, and the like; offices devoted to real estate, insurance, management, and similar enterprises when

- conducting their activities primarily by mail or telephone and not displaying or handling merchandise on the premises.
- H. Dwellings for any number of families.
 - I. Boarding and lodging houses.
 - J. Mobile home parks or trailer courts subject to the conditions as outlined in Section 165.33(2).
3. Permitted Accessory Uses.
- A. Private garages or parking areas.
 - B. Living quarters of persons employed on the premises.
 - C. Customary incidental home occupations including home daycares, beauty shops, barbershops; or dancing or music schools with more than one pupil at a time. No more than one room within the dwelling shall be used for such purposes.
 - D. Customary incidental home occupations such as handicraft dressmaking, millinery and preserving or similar activity carried on solely by resident occupants within their residence subject to the following provisions:
 - (1) No more than one room shall be used for such purposes by any resident family;
 - (2) No such use shall require internal or external alterations or involve construction features or the use of mechanical equipment not customarily in dwellings;
 - (3) Nothing is sold or offered for sale that has not been produced on the premises;
 - (4) No display of goods or services pertaining to such shall be visible from the street or road.
 - E. Signs as regulated by Section 165.27.
4. Height Regulations. No principal structure shall exceed six stories or 75 feet in height, at the required front, side, and rear yard lines, other than as provided in Section 165.33, except that one foot may be added to the height permitted for each foot that the building is set back from the required yard lines and that one foot be added to the minimum lot width for each one foot that the building exceeds six stories or 75 feet in height.
5. Lot Area, Frontage, and Yard Requirements. The following minimum requirements shall be observed, subject to the additional requirements, exceptions, and modifications in Section 165.33 inclusive. Each structure shall be located on a lot containing at least 7,500 square feet. Each structure containing more than one family shall be located on a lot having an area of 2,000 square feet for each family.

1.	1. Minimum Lot Width	1. Minimum Front Yard Depth	1. Minimum Yard Least Width	1. Side Widths Sum Least Widths	1. Minimum Rear Yard Depth
2. Story	2. 70 feet	2. 30 feet	2. 7 feet	2. 16 feet	2. 35 feet
3. Stories	3. 70 feet	3. 32 feet	3. 9 feet	3. 20 feet	3. 35 feet
4. Stories	4. 80 feet	4. 35 feet	4. 10 feet	4. 22 feet	4. 37 feet
5. Stories	5. 90 feet	5. 40 feet	5. 12 feet	5. 27 feet	5. 40 feet
6. Stories	6. 95 feet	6. 45 feet	6. 14 feet	6. 33 feet	6. 45 feet
7. Stories	7. 100 feet	7. 50 feet	7. 16 feet	7. 40 feet	7. 50 feet

Accessory buildings must be at least four feet from the lot lines.

[The next page is 1381]

165.24 GENERAL BUSINESS DISTRICTS B-1. The following are provisions of the Business Districts B-1:

1. Permitted Principal Uses.
 - A. Any use or structure permitted and as regulated in Section 165.23, except hereinafter modified.
 - B. Any retail business establishment, such as appliance store, auto accessory store, bakery with baking limited to goods for retail sales on the premises, book or stationery store, cafe or restaurant, camera or photographic supply shop, candy or ice cream store, delicatessen, drug store, fabric shop, floor-covering store, florist shop, furniture store including incidental upholstery, gift shop, grocery store, haberdashery or women's ready-to-wear shop, hardware or paint store, hobby shop, jewelry store, meat market, shoe store and variety store.
 - C. Any service establishment, such as a bank or other financial enterprise, barber or beauty shop, business or professional office, clothes cleaning or laundry pick-up station, funeral home, theater, and self-service laundry.
 - D. Animal hospitals, veterinary clinics, or kennels, provided that buildings or enclosures in which animals are kept shall be at least 100 feet from any lot in any R District.
 - E. Bus terminal.
 - F. Business or trade school.
 - G. Commercial parking lot.
 - H. Department store.
 - I. Hotel.
 - J. Meeting hall, club, or fraternal organization, where alcohol is not served.
 - K. Messenger or telegraph service stations.
 - L. Music and dancing studio.
 - M. Public parking lot, customer, and other accessory parking area, subject to the applicable provisions of Section 165.28.
 - N. Storage garages.
 - O. Auto dealership sales showrooms.
 - P. Libraries.
 - Q. The following uses when occupying a completely enclosed building located at least 100 feet from any R District;
 - (1) Dance hall, bar, or cocktail lounge, night club, and similar enterprise.
 - (2) Furniture upholstery.
 - (3) Printing, publishing, engraving, or lithographing shop.

- (4) Laundry and dry-cleaning shop.
 - (5) Plumbing shops
 - R. Tourist homes.
 - S. Building material sales yards, if enclosed on all sides by an eight-foot high solid fence.
 - T. Wholesale businesses and warehouses.
 - U. Hotels or motels, subject to the provisions of Section 165.33(2).
 - V. Drive-in facility establishments .
 - W. Farm implement sales and service.
 - X. Frozen food lockers.
 - Y. Motor fuel stations subject to the conditions stipulated in Section 165.33(2).
 - Z. Greenhouses.
 - AA. Commercial baseball field, boat house, golf driving range, skating rink, swimming pool, or similar open air recreational uses and facilities, but not within 200 feet of any R District.
 - BB. The following uses provided no part of a building where any activity is conducted shall have any openings other than stationary windows or required fire exits within 100 feet of any R District.
 - (1) Automobile, truck, trailer, and farm implement establishments for display, hire, sales, including sales lots.
 - (2) Bottling of soft drinks or milk, or distribution stations.
 - (3) Bowling alley, pool hall or billiard parlor, dance hall, bar or cocktail lounge, nightclub, and similar enterprises.
 - (4) Carpenter shop; electrical, heating, ventilating or plumbing shop; furniture upholstery shop; printing, publishing, engraving or lithographing plant; laundry and dry-cleaning shop; sign painting shop, and similar establishments.
 - CC. Any other use that is determined by the Board of Adjustment to be of the same general character as the foregoing permitted uses, but not including any use which may become noxious or offensive in a B-1 District.
2. Permitted Accessory Uses.
 - A. Accessory uses customarily incidental to a permitted use, including signs as regulated by Section 165.27.
 - B. Residential District R-1 accessory uses.
 3. Height Regulations. No structure shall exceed three stories or 45 feet in height, except as provided in Section 165.33.
 4. Lot Area, Frontage, and Yard Requirements. The following minimum requirements shall be observed, subject to the additional requirements, exceptions, and modifications in Sections 165.33, inclusive.

1.	1. Minimum Lot Area	1. Minimum Lot Area Per Family	1. Minimum Lot Width	1. Minimum Front Yard Depth	1. Minimum Side Yard Width	1. Minimum Rear Yard Depth
2. Dwellings Same As R-1 Districts						
3. Other Permitted Uses	1. None	2. None	2. None	2. None	2. None, except adjoining an R District then same as the least width required in that R District	2. 10 feet, except where adjoining an R District then same as R District

[The next page is 1389]

165.25 INDUSTRIAL DISTRICTS I-1. The following are provisions of the I-1 Industrial Districts:

1. Permitted Principal Uses.
 - A. Any use or structure permitted and as regulated in permitted principal uses of Section 165.24, except as hereinafter modified.
 - B. The following uses if located not less than 100 feet from any R District, provided any such operations are enclosed by a solid wall or fence not less than six feet in height:
 - (1) Builder's or contractor's plant or storage yard.
 - (2) Building material sales and storage yard, including concrete mixing.
 - (3) Lumber yard, including millwork.
 - (4) Open yard for storage and sale of feed, fertilizer, or fuel.
 - C. The following uses, providing no part of a building occupied by such uses shall have openings other than stationary windows or required exits within 100 feet of any R District:
 - (1) Automobile repair garage doing major repair, including tire retreading or recapping, battery service and repair.
 - (2) The manufacture, compounding, processing, packaging, or treatment of such products as bakery goods, candy, cosmetics, pharmaceuticals, toiletries, milk, and food products.
 - (3) The manufacture, compounding, assembling, or treatment of articles or merchandise from the following previously prepared material: canvas, cellophane, cloth, fiber, glass, leather, paper, plastics, precious or semi-precious metals or stone, rubber, textiles, wood, and yam.
 - (4) The manufacture or assembly of electrical appliances, electronic instruments and devices, phonographs, radio and televisions sets, electric and neon signs, refrigerators, and stoves.
 - (5) Laboratory, experimental, film, or testing.
 - D. Railroad freight stations, trucking, or motor freight terminals, provided that service yards or docks are at least 100 feet from any lot in any R District.
 - E. Sanitary landfills, in accordance with County and State regulations, except that no sanitary landfill shall be operated within 1,320 feet of any R District.
 - F. Any other use not in conflict with enacted laws of the State or City regulating nuisances that is determined by the Board of Adjustment to be of the same general character as the foregoing permitted uses, but not including any use which may become noxious in an I-1 District or offensive or emitting or likely to emit substantial amounts of dust, odor, gas, smoke, or noise. In determining the character of such use, the Board of Adjustment shall refer to the special exceptions and interpretation of the map in Section 165.35.

- G. Auto salvage and wrecking operations, industrial metal and waste salvage operations, and junk yards, but only when located inside a building or when wholly enclosed by a wooden fence not less than eight feet in height and in which the openings or cracks are less than 15 percent of the total area.
2. Permitted Accessory Uses.
- A. B-1 Business District accessory uses.
- B. Other accessory uses customarily incidental to a permitted principal use, including signs as regulated by Section 165.27.
3. Prohibited Uses.
- A. Dwellings, except for watchman or caretaker on the premises.
- B. Schools, hospitals, clinics, and other institutions for human care, except when incidental to a permitted principal use.
- C. Generation, storage, or handling of nuclear or radioactive materials.
- D. None of the following specific uses shall be permitted unless approved by the Council after a review and report from the Planning and Zoning Commission, subject to such requirements as it may deem necessary to protect adjacent property and prevent objectionable or offensive conditions:
- (1) Chemicals, petroleum, coal, and allied products:
- a. Acids and derivatives.
 - b. Acetylene.
 - c. Ammonia.
 - d. Carbide.
 - e. Caustic Soda.
 - f. Cellulose and cellulose storage.
 - g. Chlorine.
 - h. Coke oven products (including fuel gas) and coke oven products storage.
 - i. Creosote.
 - j. Distillation, manufacture, or refining of coal, tar, asphalt, wood, and bones.
 - k. Explosives (including ammunition and fireworks) and explosives storage.
 - l. Fertilizer (organic).
 - m. Fish oils and meal.
 - n. Glue, gelatin (animal).
 - o. Hydrogen and oxygen.
 - p. Lampblack, carbonblack, and boneblack.
 - q. Nitrating of cotton or other materials.

- r. Nitrates (manufacture and natural) of explosive nature and storage.
 - s. Petroleum, gasoline, and lubricating oil refining and wholesale storage.
 - t. Plastic materials and synthetic resins.
 - u. Potash.
 - v. Pyroxylin.
 - w. Rendering and storage of dead animals, offal, garbage, or waste products.
 - x. Turpentine and resin.
 - y. Wells, gas, and oil.
- (2) Clay, stone, and glass products:
- a. Brick, firebrick refractories, and clay products (coal fired).
 - b. Cement, lime, gypsum, or plaster of Paris.
 - c. Minerals and earth; quarrying, extracting, grinding, crushing, and processing.
- (3) Food and beverage:
- a. Fat rendering.
 - b. Fish curing, packing, and storage.
 - c. Slaughtering of animals.
 - d. Starch manufacture.
- (4) Metals and metal products:
- a. Aluminum powder and paint manufacture.
 - b. Blast furnace, cupolas.
 - c. Blooming mill.
 - d. Metal and metal ores, reduction, refining, smelting, and alloying.
 - e. Scrap metal reduction.
 - f. Steel works and rolling mill (ferrous).
- (5) Wood and paper products:
- a. Match manufacture.
 - b. Wood pulp and fiber, reduction, and processing.
- (6) Unclassified industries and uses:
- a. Hair, hides, and raw fur, curing, tanning, dressing, dyeing, and storage.
 - b. Stockyard or commercial feed lot.

4. Yard Requirements. The following minimum requirements shall be observed, subject to the additional requirements, exceptions, and modifications in Section 165.33, inclusive.

1. Height Permitted Uses	1. Minimum Front Yard Depth	1. Minimum Side Yard Width	1. Minimum Rear Yard Depth
2. 4 Stories or 50 feet in height	2. 25 feet	2. Equal to building height	2. Height of building but not less than 20 feet

[The next page is 1397]

165.26 MOBILE HOME PARKS. The following are provisions of Mobile Home Parks:

1. Purpose. It is the intent of this section to provide regulations for the establishment, maintenance, and operation of mobile home parks in the City.
2. Pre-Existing Mobile Home Parks. A pre-existing mobile home park shall not be deemed non-conforming by reason of failure to meet the minimum requirements prescribed by this section, provided that the regulations of this section shall apply to the enlargement or expansion of a mobile home park, and provided that a pre-existing mobile home park on a site less than 10 acres shall not be further reduced in area.
3. Mobile Home and Manufactured Home Occupancy. No mobile home or manufactured home shall be occupied or used for living or sleeping purposes unless it is affixed to a permanent foundation.
4. Criteria. Before granting a Conditional Use Permit for a mobile home park the Board of Adjustment shall make the following determination:
 - A. That the mobile home park will be located on a street or streets affording adequate access for the transportation of mobile homes and manufactured homes into and out of the mobile home park without undue inconvenience or interference with normal vehicular traffic and circulation in the neighborhood;
 - B. That the mobile home park will be located and developed in a manner that permits adequate circulation to and within the proposed development for emergency and protective services, including police and fire equipment.
5. Site Standards. The following regulations shall apply to the site of a mobile home park. Additional regulations may be specified as conditions of a use permit.
 - A. The minimum site area is 10 acres and each boundary line of the park shall be at least 200 feet from any residential structure located outside the park unless separated therefrom by a natural or artificial barrier.
 - B. The park shall be located on a well-drained site, properly graded to insure rapid drainage and freedom from stagnant pools of water.
 - C. The minimum frontage is 250 feet, continuous frontage on a dedicated public street.
 - D. The minimum site area per unit is seven units per net acre.
 - E. The minimum yard width is 25 feet adjoining a street; 15 feet adjoining an interior lot line.
 - F. The maximum height of any mobile home or manufactured home is 20 feet.
 - G. Perimeter roads shall be required subject to City staff approval. This requirement can be waived by the Council provided approved alternatives are offered.
 - H. All mobile home, manufactured home, or modular home spaces shall abut upon a driveway of not less than 20 feet in width which shall have unobstructed access to a public street.

- I. All driveways and walkways in the park shall be hard surfaced and lighted at night with electric lamps of not less than 25 watts each, spaced at intervals of not more than 100 feet.
- 6. Interior Site Development. The following requirements shall apply to development of mobile home park lots and to facilities within a mobile home park. In addition, each park shall comply with the regulations set forth by the General Assembly of Iowa. Additional requirements may be specified as conditions of a use permit:
 - A. Mobile Home Park Lot. Each lot shall contain a minimum of 4,400 square feet for exclusive use by the occupants of the lot. Each lot shall be at least 40 feet wide abutting a private or public street. Each lot shall have minimum dimensions of 55 feet by 80 feet.

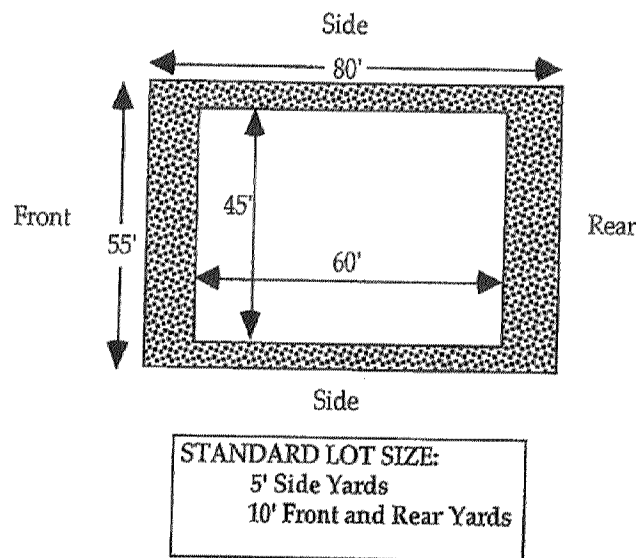

- B. Mobile Home or Manufactured Home Placement. Every lot shall have a front and rear yard of not less than 10 feet in depth. All lots shall have a minimum of five-foot side yard on each side of the lot. A mobile home, manufactured home, and related structures shall not occupy more than 60 percent of the area of any mobile home park lot.
- Tiedowns for each mobile home, manufactured home, or modular home as required of State law.
- C. Access Drives. All mobile home park access drives within a mobile home park shall be privately owned, and shall be at least 30 feet wide exclusive of adjoining parking areas.
- D. Sidewalks. Concrete sidewalks at least five feet in width shall be provided to serve all central or common facilities within the mobile home park.
- E. Landscaping. Not less than 20 percent of each mobile home park lot shall be landscaped with live plant materials, including at least one tree on each lot.

F. Screening and Landscaping.

(1) Where a site adjoins a single-family dwelling zone, or a site that is generally planned for low density single-family use, a solid masonry wall six feet in height shall be located adjoining the property line, except adjoining a required front yard; and an area at least five feet in depth adjoining the property line shall be landscaped with live plant materials including trees. Where a carport or garage is placed within three feet of a property line adjoining a single-family use, no landscaped buffer is required;

(2) All areas to be used for the outdoor handling and drying of laundry shall be screened from view;

(3) Required yards shall be landscaped in accord with a site development plan to be approved as a part of the use permit, and screening shall be provided around the entire site, except that where a required yard adjoins a street, screening shall be located at the rear of the required yard.

G. Electrical and Telephone Services. All electrical, telephone, CATV, and similar service wires or cables which provide direct service to the property being developed shall, within the exterior boundary lines of such property, be installed underground. An electrical outlet supplying at least 110 volts shall be provided for each mobile home, manufactured home, or modular home space. Risers on poles and buildings are permitted and shall be provided by the developer or owner onto the pole which provides service to said property. Utility service poles may be placed on the rear of the property to be developed, only for the purpose of terminating underground facilities. The developer or owner is responsible for complying with the requirements of this section and they shall make the necessary arrangements for the installation of such facilities. For the purpose of this subsection, appurtenances and associated equipment such as surface mounted transformers, pedestal-mounted terminal boxes, and meter cabinets may be placed above ground.

H. Water and Wastewater Services. Adequate sanitary facilities and supply of pure water shall be provided to each mobile home, manufactured home, or modular home space.

7. Community Recreation.

A. Open Space. A minimum of 270 square feet per mobile home park lot of recreation area, exclusive of any mobile home park lot, shall be provided within the mobile home park for recreational and leisure activities. Open space may include a recreation building, outdoor or indoor game courts, putting greens, golf courses, swimming pools and spas, tennis courts, maintained greenbelts, and other similar facilities.

B. Recreation Building. A recreation building shall be provided for the use and enjoyment by all residents. The building shall have a minimum gross floor area of 25 square feet per residential lot and shall contain facilities for the preparation and cooking of food, restrooms, and storage facilities.

C. Demonstration of Recreation Areas. The community recreation and service area, as aforesaid, together with the activities planned thereon, shall be

shown on the plans for development from time to time. The location and size of all facilities indicated in this paragraph shall be subject to the approval of the Planning and Zoning Commission and Council.

D. Membership Fees. Nothing contained in this subsection shall be construed as limiting the ability of an owner or owners of community recreational facilities of imposing membership or maintenance fees for the use of such facilities.

E. Accessory Buildings and Uses. Each mobile home park shall provide service buildings to house such toilet, bathing, and other sanitary facilities and such laundry facilities as may be prescribed .

Accessory buildings and uses serving the entire mobile home park, including recreation facilities, laundry areas, mobile home park offices, maintenance, and storage areas shall be located at least 50 feet from the boundary of the mobile home park.

8. Improvement Requirements. On-site improvements shall be constructed and maintained in conformance with mobile home park improvement standards, approved by the Planning and Zoning Commission and Council. Such standards may include, but shall not be limited to, the design, construction, and maintenance of the following:

- A. Access drives, sidewalks, and parking spaces;
- B. Walls and fences;
- C. Lighting;
- D. Curb and gutter, drainage, and sanitary sewer facilities;
- E. Electrical and water services;
- F. Fire protection;
- G. Refuse collection facilities.

[The next page is 1405]

165.27 SIGNS. The following are provisions on signs in the City:

1. Standard of Measurement.
 - A. The total area of all signs permitted on a lot shall include:
 - (1) The total area of the faces visible from a public way of all permanent exterior signs, plus
 - (2) The area of permanent signs placed upon the surface of windows and doors, plus
 - (3) The area within the outline enclosing the lettering, modeling, or insignia of signs integral with the wall and not designed as a panel.
 - B. A building or use having frontage on a second street may include 20 percent of the length of the lot facing the second street.
2. Signs Permitted in the A-1 District.
 - A. Signs not exceeding four square feet in area indicating the type of plant being grown or the type of fertilizer being used.
 - B. Signs not exceeding 20 square feet in area pertaining to a permitted recreation use or areas of scenic beauty provided such signs shall be set back at least 10 feet from any right-of-way and there shall be a distance of 300 feet between any such signs.
 - C. Signs accessory to roadside stands shall be limited to two signs per lot with no sign being larger than 10 square feet in area and set back at least 10 feet from the right-of-way of a street, highway, or road.
 - D. Real estate signs of a temporary nature, not exceeding two in number per lot nor larger than 12 square feet, set back four feet from the right-of-way of any highway, street, or road.
 - E. Small announcement or professional signs, not over six square feet in area, except that an announcement sign or bulletin board not over 18 square feet in area set back at least four feet from the right-of-way of any highway, street, or road, may be erected in connection with any of the permitted principal uses of non-residential nature.
 - F. No billboard, signboard, or similar advertising signs shall be located at intersections so as to obstruct vision, hearing, or interfere with pedestrian or vehicular safety.
3. Signs Permitted in All Residential Districts.
 - A. Real estate signs of a temporary nature, not exceeding two in number per lot nor larger than six square feet set back five feet from the right-of-way of any highway, street, or road.
 - B. A sign or signs flat against a building appertaining to a non-conforming use on the premises, not exceeding in the aggregate of 50 square feet in area except as may be authorized by the Board of Adjustment.
 - C. Small announcement sign or bulletin board not over 18 square feet in area, with a setback at least 20 feet from the right-of-way of any highway, street,

- or road, may be erected in connection with any of the permitted principal uses of non-residential nature.
- D. One nameplate not exceeding four square feet for each dwelling.
4. Signs Permitted in the B-1 District.
- A. Signs as permitted and regulated for all residential districts in Section 165.27(3), except as hereinafter modified.
- B. The total area of all signs permitted on any one lot shall not exceed two times the number of linear feet the lot abuts on the street.
- C. Projecting signs at least eight feet above the sidewalk and extending no further than five feet from the building to which it is attached.
- D. Billboard and signboards subject to the same height and location requirements as other structures in the B-1 District and also subject to the following conditions and restrictions:
- (1) No billboard, signboard, or similar advertising signs shall be located at intersections so as to obstruct vision, hearing, or interfere with pedestrian or vehicular safety.
 - (2) No billboard, signboard or similar advertising signs shall be located within 50 feet of any lot in an R-1 District.
 - (3) No billboard or signboard shall exceed 300 square feet in area.
 - (4) No billboard, signboard, or similar advertising signs shall be so constructed or located where it will unreasonably interfere with the use and enjoyment of adjoining property.
- E. Elevated signs at least five feet from any lot line.
- F. Projecting signs at least eight feet above the sidewalk and extending no further than five feet from the building to which it is attached.
5. Signs Permitted in the I-1 District.
- A. Signs as permitted and regulated in the B-1 District of Section 165.27(4).

[The next page is 1411]

165.28 OFF-STREET PARKING AREAS AND LOADING SPACES.

1. Off-Street Loading. In all districts, in connection with every building or part thereof hereafter erected, having a gross floor area of 2,500 square feet or more, which is to be occupied by uses requiring the receipt or distribution by vehicles of materials or merchandise, there shall be provided and maintained on the same premises with such building at least one off-street loading space accessible from an alley, easement of access, or, when there is no such alley or easement of access, from a street plus one additional such loading space for each 10,000 square feet or major fraction thereof of gross floor area so used in excess of 15,000 square feet. Such space may occupy all, or any part of a required rear yard, or, with authorization of the Board of Adjustment, part of any other yard or court space on the same premises.

2. Off-Street Parking. In all districts except B-1 District, off-street accessory parking areas, in the open or in a garage, shall be provided in connection with the uses set forth hereinafter and to the extent indicated therewith, in addition to the above required loading and unloading spaces. Such areas, in the case of R Districts and for dwellings in other districts, shall be on the premises intended to be served; and in the case of B-1 or I-1 Districts, premises intended to be served or on adjoining or nearby property within 100 feet of any part of said premises and in the same or less restricted district.

1. Number of Parking Spaces Required	
2. Use	1. Parking Spaces Provided
3. Automobile or machinery sales and service garages	2. One for every 1,000 square feet of floor area plus one for each full-time employees
4. Banks, business, and professional offices	3. One for every 200 square feet of floor area
5. Bowling alleys	4. Six for each bowling lane
6. Churches and schools	5. One for every four seats in principal auditorium
7. Convenience stores, drug stores, grocery stores, hardware stores, and similar stores	6. One for every 300 square feet of floor area devoted to sales, plus one for each full-time employee
8. Dance halls and assembly halls without fixed seats	7. One for every 50 square feet of floor area used for assembly or dancing
9. Drive-in facilities	8. Not less than 1/3 of the total ground area should be devoted to parking and accessways
10. Dwellings	
11. Single-family detached	1. Two for each dwelling unit
12. All other	2. One and one-half for each dwelling unit
13. Food pick-up establishments	3. Minimum of one, plus one for every 100 square feet of floor area
14. Funeral homes, mortuaries	4. Six per chapel room or parlor, or one per every 50 square feet of rooms used for services, whichever is greater

1. Number of Parking Spaces Required	
2. Use	1. Parking Spaces Provided
15. Hospitals, nursing homes, and similar care centers	5. One for every five beds, plus one for every two doctors and employees
16. Manufacturing plants, research or testing laboratories, or bottling plants	6. One for every three employees on maximum working shift
17. Medical or dental clinics	7. One for every 200 square feet of floor area, plus one for each full-time employee and one for each doctor
18. Motels or hotels	8. One for each unit, plus one for every two employees on maximum shift
19. Motor fuel stations	9. One for each employee on duty, plus one for each service bay
20. Service Establishments	
21. Barber shops	1. Two for each chair, plus one for every two employees on maximum shift
22. Beauty shops	2. One for each dryer, plus one for every two employees on maximum shift
23. Coin operated laundries or dry-cleaning establishments	3. One for every three washers or cleaning machines, plus one for every two employees on maximum shift
24. Restaurants	4. One for every three seats, plus one for every two employees on maximum shift
25. Shopper's goods - appliance stores, household equipment stores, furniture stores, and similar stores	5. One for every 500 square feet of floor area, plus one for each full-time employee
26. Taverns or bars	6. One for every two seats plus one for every two employees on maximum shift
27. Theaters	7. One for every four seats
28. Wholesale establishments	8. One for every four employee on maximum work shift
29. In the case of any use which is not specifically mentioned herein, the provisions for a similar use which is mentioned shall apply.	

3. Units of Measurement. The following shall apply as the unit of measurement for parking spaces:

- A. Parking Space. Each parking space rectangular in shape shall not be less than eight and one-half feet wide and 20 feet long, or not less than 170 square feet in area exclusive of access drives or aisles.
- B. Loading Space. Each loading space shall not be less than 10 feet wide, 40 feet in length, and 14 feet in height, exclusive of access and turning area.
- C. Floor Area. In the case of merchandising or service types of uses, floor area shall mean the gross floor area used or intended to be used by tenants, or for service to the public as customers, patrons, or clients, but shall not include areas used principally for non-public purposes, such as toilet or restrooms, utilities, or dressing rooms.

D. Hospital Bassinets. In hospitals, bassinets shall not be counted as beds.

E. Benches in Place of Public Assembly. In stadiums, sports arenas, churches, and other places of public assembly in which patrons or spectators occupy benches, pews, or other similar seating facilities, each 20 inches of such seating facilities shall be counted as one seat for the purposes of determining requirements for off-street parking facilities under this Zoning Code.

4. Development Standards. Off-street accessory parking areas shall be of usable shape, and shall be improved, in accordance with requirements of the City Engineer, or their equivalent, with a durable and dustless surface and so graded and drained as to dispose of all surface water accumulation within the area. Any lighting used to illuminate such parking areas shall be so arranged as to reflect the light away from adjoining premises in any R District.

5. Exceptions. The following exceptions to parking spaces are permitted:

A. The Board of Adjustment may authorize, on appeal, a modification, reduction, or waiver of the foregoing requirements, if it should find that in the particular case the peculiar nature of the use, or other exceptional situation or conditions would justify such modifications, reduction, or waiver.

B. The Planning and Zoning Commission, in consultation with other City departments and agencies concerned, shall make studies as found advisable of various areas in the City for the purpose of determining the areas within which there is need for the establishment of off-street parking facilities to the Council. This report shall include recommendations on the type, size, location, and other pertinent features of the proposed off-street parking facilities and the area they are intended to serve.

165.29 DESIGNATED FLOOD HAZARD AREA. All buildings and land within a designated flood hazard area as defined by the Department of Housing and Urban Development shall be limited to the following uses:

1. The growing of agricultural crops and nursery stock gardening.
2. The keeping of agricultural livestock in accordance with the municipal ordinance relating there to.
3. Public recreation.
4. No building shall be erected, converted, or enlarged on any parcel of land without the approval of the Zoning Board of Adjustment.

165.30 GARAGES; MOTOR FUEL STATIONS; AND CAR WASHES.

1. No building, structure, or premises shall be used, erected, or altered which is intended or designed to be used as a public garage, automobile repair shop, motor fuel station, or car wash having an entrance or exit for vehicles in the same block-front and within 200 feet of any school, public playground, church, hospital, public library, or institution for dependents or for children, and no such entrance or exit shall be located within the same block-front and within 20 feet of any R District; nor shall any part of such public garage, automobile repair shop, motor fuel station, or car wash be located within 100 feet of any building or grounds of any of the aforesaid public or institutional uses.

2. All activities incidental to the sale of gasoline or oil such as battery and tire repair, car washing and greasing shall be conducted within the building and there shall be no storage or accumulation of miscellaneous equipment, machinery, or motor vehicles, disabled or otherwise, outside of the principal structure.
3. No above ground storage for volatile or explosive fuels will be permitted.

165.31 TRAILERS; RECREATIONAL VEHICLES AND TENTS.

1. The parking of a trailer or recreational vehicle, or erections of a tent in any district, except in an approved trailer park or camp ground, for 48 hours or longer shall be prohibited, except for small utility trailers and except that a camping, utility, or boat trailer, with or without boat, may be stored on the property except in front yards, provided that no living quarters shall be maintained or any business conducted in connection therewith while such trailer is parked or stored.
2. In any district, the wheels of any trailer or recreational vehicle shall not be removed except for repairs, nor shall such trailer be otherwise permanently fixed to the ground by any person, firm, or corporation in a manner that would prevent ready removal of said trailer.

165.32 HOTELS AND MOTELS.

1. No vehicular entrance to or exit from any hotel or motel, wherever such may be located, shall be within 200 feet along streets from any school, public playground, church, hospital, library, or institution for dependents or for children, except where such property is in another block or on another street, which the premises in question do not abut.
2. The following regulations shall be complied with:
 - A. Any lot to be used for a hotel or motel shall be not less than 15,000 square feet in area and shall contain not less than 1,000 square feet of lot area per sleeping unit. All buildings and structures on the lot shall occupy in the aggregate not more than 25 percent of the area of the lot.
 - B. All areas used for automobile access parking shall comply with the provisions of off-street parking areas and loading spaces under Section 165.33(2).
 - C. All areas not used for access, parking, circulation, buildings, and services shall be completely landscaped and the entire site maintained in good condition.
 - D. No enlargements or extensions to any motel shall be permitted unless the existing one is made to conform substantially with all the requirements for new construction for such an establishment.

165.33 ADDITIONAL REQUIREMENTS, EXCEPTIONS, AND MODIFICATIONS.

The following are additional requirements, exceptions, and modifications to be considered in this Zoning Code:

1. The requirements and regulations specified here-to-fore in the Zoning Code shall be subject to the additional requirements, exceptions, modifications, and interpretations in the following.

2. Height Limits. Height limitations stipulated elsewhere in this report shall not apply to the following:

A. Barns, silos, or other farm buildings or structures on farms, provided these are not less than 50 feet from every lot line; to church spires, belfries, cupolas, and domes, monuments water towers, fire and hose towers, masts, and aerials; to parapet walls extending not more than four feet above the limited height of the building. However, if, in the opinion of the Building Inspector or their equivalent, such structures would adversely affect adjoining or adjacent properties, such greater height shall not be authorized except by the Board of Adjustment.

B. Places of public assembly such as churches, schools, and other permitted public and semi-public buildings not to exceed six stories or 75 feet, provided that, for each foot by which the height of such building exceeds the maximum height otherwise permitted in the district, its side and rear yards shall be increased in width or depth by an additional foot over the side and rear yards required for the highest building otherwise permitted in the district.

C. Bulkheads, conveyors, derricks, elevator penthouses, water tanks, monitors and scenery lofts; to monuments, fire towers, hose towers, cooling towers, grain elevators, gas holders, or other structures, where the manufacturing process requires a greater height. Where a permitted use requires greater heights than specified, such may be authorized by the Board of Adjustment.

3. Front Yard Exceptions and Modifications.

A. Front Yard Requirements Do Not Apply. To bay windows or balconies occupying in the aggregate not more than one third of the front wall; to chimneys, flues, belt courses, leaders, sills, pilasters, uncovered porches, plantings, or similar features not over three feet high above the average finished grade and distant five feet from every lot line.

B. Permitted Variations. In any district where the average depth of two or more existing front yards on lots within 100 feet of the lot in question and within the same block front is less or greater than the least front yard depth prescribed, front yards may be varied. The depth of the front yard on such lots shall not be less than the average of said existing front yards or the average depth on the two lots immediately adjoining, or in the case of a corner lot, the depth of the front yard on the lot immediately adjoining; provided, however, that the depth of a front yard on a lot in any R District shall be at least 15 feet and need not exceed 60 feet.

4. Side Yard Exceptions and Modifications.

A. Along any district boundary line, any abutting side yard on a lot in the less restricted district shall have at least width equal to that required in the more restrictive district. Where a lot in an I or B District abuts a lot in any R District, the side yard shall be increased by three feet for each story that the building proposed on such lot exceeds the height limit of said R District.

B. Side Yards Shall be Increased. In width by two inches for each foot by which the length of the side wall of the building, adjacent to the side yard, exceeds 40 feet in any R-1 District.

- C. Side Yards May be Reduced. By three inches from the otherwise required least width of each side yard for each foot by which a lot of record at the time of enactment of the Code is narrower than the lot width specified for the district in which the lot is located, in the case of buildings not higher than two and one-half stories, and in case the owner of record does not own any adjoining property; provided, however, and irrespective of the provision of structures or projections into side yards of Section 165.33 that no side yard shall be narrower at any point than three feet.
- D. Side Yards May be Measured to the Center Line of Adjoining Alleys. But in no case shall a building or structure for which a side yard is required be erected within five feet of such alley.
- E. On a Comer Lot. The least width of a side yard along the side street lot line shall be equal to the required front yard along the side street.
- F. Structures or projections in to side yards may be permitted as follows: fences, plantings, or walls not over five feet above the average natural grade. Fire escapes, three feet from side lot line. Bays and balconies not more than three feet from the building. The sum of the lengths of such projection shall not exceed one third of the length of the wall of the main building.
- (1) Chimneys, flues, belt courses, leaders, sills, pilasters, and lintels, ornamental features, cornices, eaves, gutters, and the like into or over a required side yard not more than one and one-half feet.
 - (2) Terraces, steps, uncovered porches, stoops, or similar features, not higher than the elevation of the ground story of the building and distant three feet from a side lot line.
5. Rear Yard Exceptions and Modifications.
- A. Rear yards May be Reduced. By three inches from the required least depth for each foot by which a lot at the time of enactment of the Code is less than 100 feet deep, in the case of a building not higher than two and one-half stories and in case the owner of record does not own adjoining property to the rear; provided however that no required rear yard shall be less than 10 feet deep.
- B. Rear Yards May be Measured to the Center Line of Adjoining Alleys. But in no case shall a building or structure be erected within 10 feet of such an alley.
- C. Structures or Projections into Rear Yards May be Permitted as Follows. Fences, plantings, or walls not over five feet above the average natural grade. Fire escapes hanging no lower than six feet above the natural grade, unless they are permanently affixed to the ground. Bays and balconies, not more than three feet above the natural grade. The sum of the lengths of such projections shall not exceed one-half of the width of the rear wall. Chimneys, flues, belt course, leaders, sills, pilasters, lintels, ornamental features, cornices, eaves, gutters, and the like, into or over a required rear yard not more than one and one-half feet.

165.34 ZONING ADMINISTRATION.

1. Administration. It shall be the duty of the person designated by the Mayor and Council as administrative officer to administer and enforce the regulations contained herein. This person is designated the Zoning Administrator.

2. Appointment of Zoning Administrator. The Zoning Administrator shall be appointed by the Council. It shall be the duty of the Zoning Administrator to enforce this Code. All departments, officials, and public employees of the City, vested with the duty or authority to issue permits or licenses, shall conform to the provisions of this Code and shall issue no permit or license for any use, building, or purpose in conflict with the provisions of this Code. Any permit or license, issued in conflict with the provisions of the Code, shall be null and void.
3. Powers and Duties of the Zoning Administrator. The Zoning Administrator shall enforce the Zoning Code, and in addition thereto and the furtherance of said authority shall:
 - A. Receive all applications for permits required by this Zoning Code and take action on the application.
 - B. Investigate all appropriate facts and conditions of the application and upon positive analysis shall issue all zoning certificates and maintenance thereof.
 - C. Issue all occupancy permits and make and maintain records thereof.
 - D. Ensure inspection of buildings, structures, and use of land to determine compliance with the terms of the Zoning Code.
 - E. Maintain permanent and current records of the Zoning Code including, but not limited to, all maps, amendments, uses on review, variances, etc.
 - F. Provide and maintain a public information service relative to all matters arising out of the Zoning Code.
 - G. Forward to the Council and the Planning and Zoning Commission all applications for amendments to the Zoning Code.
 - H. Transmit to the Board of Adjustment applications for appeals, variances, uses on review, or other matters on which the Board of Adjustment is required to pass under the Zoning Code.
 - I. Initiate, direct, and review, from time to time, a study of the provisions of the Zoning Code and make reports of their recommendations to the Planning and Zoning Commission, Board of Adjustment, or Council.
4. Filing Plans. Every application of a building permit shall be filed with the Zoning Administrator, accompanied by plans in duplicate, drawn to scale on the form, showing the actual shape and dimensions of the lot to be built upon or to be changed in its use, in whole or in part; the exact locations, size, and height of any building or structure to be erected or altered; in the case of a proposed new building or structure or proposed alteration of an existing building or structure as would substantially alter its appearance, drawings or sketches showing the front, side, and rear elevations of the proposed building or structure, or of the structure as it will appear after the work for which a permit is sought shall have been completed; the existing and intended use of each building or structure or part thereof; the number of families or housekeeping units the building is designed to accommodate; and when no buildings are involved, the locations of the present use and proposed use to be made of the lot; and such other information with regard to the lot and neighboring lots as may be necessary to determine and provide for the enforcement of this Zoning Code. One copy of such application and plans shall be returned to the applicant when such plans shall have been approved by the Zoning Administrator, together with such building permit as may be granted. All

dimensions shown on these plans related to the location and size of the lot to be built upon, shall be based on actual survey. The lot and the location of the building hereon, shall be staked out on the ground before construction is started.

5. Certificate of Approval. In every case where the lot is not provided with the disposal of sanitary wastes by means of public sewers, the application shall be accompanied by Certificate of Approval by the Zoning Administrator of the proposed method of disposal of sanitary wastes and proof of conformance to State and federal public health and water pollution codes.

6. Building Permit. It shall be unlawful for any owner, lessee, or tenant to use or permit the use of any structure, building, or land, or part thereof, hereafter created, erected, changed, converted, or enlarged, wholly or partly until a building permit shall show that such building or premises or a part thereof, and the proposed use thereof, and the proposed methods of water supply and disposal of sanitary wastes, conform with all the requirements of this Zoning Code.

7. Building Plan Required - Fee. All applications for building permits shall be accompanied by a plat drawn to scale, showing the actual dimensions of the lots to be built upon, the size and location of the building to be erected and such other information as may be necessary to provide for the enforcement of these regulations. No building permit shall be issued until a fee of \$25.00 shall have been paid.

8. Posting of Permits. All permits shall be clearly posted, readily visible from the public street abutting the front lot line.

9. Certificate of Occupancy. It shall be unlawful for any owner, lessee, or tenant to occupy any structure, building or land, or part thereof, hereafter erected, created, changed, converted, or enlarged, until a Certificate of Occupancy shall have been issued by the Zoning Administrator after inspection. Such Certificate of Occupancy shall show and certify that such building, structure, or premises has been constructed, altered, or improved in compliance with the provisions of the Code, and all other applicable codes or ordinances and all conditions and requirements, if any, stipulated by the Board of Adjustment or other proper authority.

10. Administrator to Act Within 30 Days. The Zoning Administrator shall act upon all such applications on which they are authorized to act by the provisions of the Zoning Code within 30 days after they are filed in full compliance with all the applicable requirements. They shall either issue a building permit within said 30 days or shall notify the applicant in writing of the refusal to such certificate and the reasons therefore. Failure to notify the applicant in case of such a refusal within said 30 days shall entitle the applicant to a building permit unless the applicant consents to an extension of time.

11. Records of the Zoning Administrator. The Zoning Administrator shall keep accurate records pertaining to actions necessary to carry out the duties in this Zoning Code. These records shall be on file for public inspection.

165.35 BOARD OF ADJUSTMENT.

1. Creation, Membership, and Procedure. A Board of Adjustment consisting of five or seven members which are appointed by the Council as provided by Chapter 414.8 of the 1981 *Code of Iowa*, is hereby created. Members of a five-member board shall be appointed for a term of five years, except that when the Board of Adjustment shall first be created one member shall be appointed for a term of five years, one for a term of four years, one for a term of three years, one for a term of two years, and one

for a term of one year. Members of a seven-member board shall be appointed for a term of five years, except when the Board shall first be created two members shall be appointed for a term of five years, two members for a term of four years, one for a term of three years, one for a term of two years, and one for a one-year term. A majority of members of the Board of Adjustment shall be persons representing the public at large and shall not be involved in the business of purchasing or selling real estate. Vacancies shall be filled for the unexpired term of any member whose term becomes vacant. The appropriate appointing authority may remove any member of the Board of Adjustment for cause and after public hearing.

A. Organization. The Board of Adjustment shall elect its own officers and shall have the power to adopt rules and regulations for its own government, not inconsistent with law or with the provisions of the Zoning Code or any other ordinances of the City. Meetings shall be held at the call of the Chairperson and at such other times as the Board of Adjustment may determine. In the absence of the Chairperson, the acting Chairperson may administer oaths and compel attendance of witnesses.

B. Meetings. Meetings of the Board of Adjustment shall be open to the public, minutes shall be kept of the proceedings, showing the action of the Board of Adjustment and the vote of each member upon each question, or if absent or failing to vote, indicating that fact, and records shall be made of the Board of Adjustment's examination and other official action, all of which shall be filed immediately in the office of the Board of Adjustment as a public record.

C. Quorums. Three members of a five-member Board of Adjustment shall constitute a quorum, and four members of a seven-member board shall constitute a quorum. The Board shall act by resolution, and the concurring votes of three members of a five-member board, and four members of a seven-member board shall be necessary to reverse any order, requirements, decision, or determination of the Building Inspector, or to decide in favor of an applicant any matter upon which it is required to pass under the Zoning Code or to effect variation in the requirements of the Zoning Code.

D. Assisting Board of Adjustment. The Board of Adjustment may call on the City departments for assistance in the performance of its duties, and it shall be the duty of such departments to render such assistance to the Board of Adjustment as may reasonably be required.

2. Applications and Appeals.

A. Applications. An application to the Board of Adjustment, in cases in which it has original jurisdiction under the provision of the Code, may be taken by any property owner, including a tenant, or by any governmental officer, department, board, or bureau. Such application shall be filed with the Zoning Administrator, together with a fee of \$25.00, who shall transmit the same, together with all the plans, specifications and other papers pertaining to the application to the Board of Adjustment. Should the applications be withdrawn prior to publication of legal notice thereon, such fee will be returned upon written request of the applicant.

B. Appeals. An appeal to the Board of Adjustment may be taken by any property owner, including a tenant, or by any governmental officer, department, board, or bureau affected by any ruling of the Zoning Administrator. Such an

appeal shall be taken within a reasonable time, as prescribed by the rules of the Board of Adjustment, by filing with the Zoning Administrator a notice or appeal specifying the grounds thereof. The Zoning Administrator shall forthwith transmit to the Board such notice of appeal, together with all the plans and papers constituting the record upon which the action appealed from was taken. A fee of \$25.00 shall also accompany the appeal. Should the appeal be withdrawn prior to publication of legal notice thereon, such fee will be returned upon written request of the applicant.

C. Hearings. The Board of Adjustment shall fix a reasonable time for the hearing of an application or of an appeal. It shall give at least four days' notice of the time and place of such hearing by insertion in a newspaper published in the community, and shall also give notice delivered by first class mail at least five days before the time fixed for such hearing to the applicant or appellant and to the Zoning Administrator, and to the respective owners of record of property adjoining or adjacent to the premises in question. Any party may appear at such hearing in person or by agent or by attorney. The Board of Adjustment shall decide the application or appeal within a reasonable time.

D. Stay of Proceedings. An appeal shall stay all proceedings in furtherance of the action appealed from, unless the Zoning Administrator certifies to the Board of Adjustment that, by reason of facts stated in the certificate, a stay would in their opinion cause imminent peril to life or property. In such case, proceedings shall not be stayed otherwise than by order which may, on due cause shown, be granted by the Board on application, after notice to the Zoning Administrator or by court of record.

3. Powers of the Board of Adjustment. The Board of Adjustment shall have jurisdiction in matters and shall have the specific and general powers provided in this Zoning Code and by the *Code of Iowa*.

A. Special Exceptions and Interpretation of Map. The Board of Adjustment shall have the power to hear and decide, in accordance with the provisions of the regulation, requests, or applications for special questions upon which the Board of Adjustment is authorized to pass.

B. Special Exceptions. In addition to permitting the special exceptions heretofore specified in this Zoning Code, the Board of Adjustment shall have authority to permit the following:

(1) Non-Conforming Uses. The substitution for a non-conforming use, another non-conforming use, if no structural alterations except those required by law are made; provided, however, that any use so substituted shall be of the same or a more restricted classification.

(2) Temporary Uses and Permits.

a. The temporary use of a building or premises in any district for a purpose of use that does not conform to the standards prescribed by the regulations, provided that such use be of a true temporary nature and does not involve the erection of substantial buildings. Such permit shall be granted in the form of a temporary and revocable permit for not more than a 12-month period, subject to such conditions as will safeguard the public health, safety, convenience, and general welfare.

- b. The temporary use of a building or premises in undeveloped sections for a purpose that does not conform to the standards prescribed by the regulations, provided that such structure or use is of a true temporary nature, is promotive of or incidental to the development of such undeveloped sections, and does not involve the erection of substantial buildings. Such permit shall be granted in the form specified under Subsection 2(A) above.
 - (3) Interpretation of Map. Where the street or lot layout actually on the ground or as recorded, differs from the street and lot lines indicated on the Official Zoning Map, the Board of Adjustment, after notice to the owners of the property and after public hearing, shall interpret the map in such a way as to carry out the intent and purposes of the regulations for the particular section or district in question.
 - (4) Certain Industries in I-1 Districts. In determining whether certain uses shall be located in a I-1 District, the Board of Adjustment shall give due regard to the nature and condition of all adjacent uses and structures, and the consistency therewith of the proposed use and development. Before authorizing a use as a special exception, the Board of Adjustment shall determine whether the proposed exception or use would be hazardous, harmful, noxious, offensive, or a nuisance to the surrounding neighborhood by reason of noise, smoke, odor, vibration, dust and dirt, cinders, noxious gases, glare and heat fire and safety hazards, sewage wastes and pollution, transportation and traffic, aesthetic, and physiological effect. The Board of Adjustment may utilize and give recognition to those performance standards which are available in model codes or ordinances, or have been developed by planning, manufacturing, health, architectural, and engineering research organizations, and can be applied to the proposed use to assist in reaching a fair and objective decision. Upon authorizing a special use or exception, the Board of Adjustment may impose such requirements and conditions in addition to those expressly stipulated in this report for the particular special use or exception as the Board of Adjustment may deem necessary for the protection of adjacent properties and public interest.
- C. Administrative Review and Variances. The Board of Adjustment also shall have the power to do the following:
- (1) Administrative Review. To hear and decide appeals where it is alleged by the appellant that there is error in any order, requirement, decision, grant, or refusal made by the Zoning Administrator in the enforcement of the regulation.
 - (2) Variances. To authorize an appeal in specific cases, such variance from the terms of the regulations as will not be contrary to the public interest, where, owing to special conditions, a literal enforcement of the provisions of the regulations will result in unnecessary hardship, and so that the spirit and purpose of the regulations shall be observed and substantial justice done as follows:

a. Where, by reason of exceptional narrowness, shallowness, or shape of a specific piece of property at the time of enactment of the regulations, or by reason of exceptional topographic conditions, or other extraordinary and exceptional situation or condition of such piece of property, or of the use or development of property in question, the literal enforcement of the provisions of the regulations would result in peculiar and exceptional practical difficulties or exceptional and undue hardships, and so that the spirit and purpose of the regulations shall be observed and substantial justice done. In authorizing a variance, the Board of Adjustment may attach thereto such conditions regarding the location, character, and other features of the proposed building, structure, or uses as it may deem advisable in the interest of the furtherance of the purposes of the regulations.

b. No such variance in the provision or requirements of the regulations shall be authorized by the Board unless the Board finds beyond reasonable doubt that all of the following conditions exist:

(i) That there are exceptional or extraordinary circumstances or conditions applying to the property in question or to the intended use of the property that do not apply to other properties or class of uses in the same zoning district.

(ii) That such variance is necessary for the preservation and enjoyment of a substantial property right possessed by other properties in the same zoning district and in the vicinity.

(iii) That the authorizing of such variance will not be of substantial detriment to adjacent property and will not materially impair the purposes of the regulations or the public interest.

c. No grant or variance shall be authorized unless the Board of Adjustment specifically finds the condition or situation of the specific piece of property for which the variance is sought is not of so typical or recurrent a nature as to make reasonably practicable the formulation of a general regulation, under an amendment of the regulations, for such conditions or situations.

d. The Board shall have no power to authorize a variance for the establishment of a non-conforming use where none previously existed.

e. In considering a request for a variance from the regulations concerning signs, the Board of Adjustment shall give consideration and arrive at a finding on the following:

(i) Shape and area of lot in question.

- (ii) Bulk and floor area of the main building or structure.
- (iii) Setback of proposed sign from all property lines.
- (iv) Zoning and use of surrounding parcels.
- (v) Unusual or exceptional topography.
- (vi) Compatibility with general intent of the zoning regulations to encourage development without detracting from the use and enjoyment of surrounding property.

f. Action of Board of Adjustment. In exercising its powers, the Board of Adjustment may, in conformity with the provisions of the *Code of Iowa*, and of the regulations, reverse or affirm, wholly or partly, or may modify the order, requirement, decision, or determinations as, in the Board of Adjustment's opinion, ought to be made, and to that end has all the powers of the officer from whom the appeal is taken.

4. Judicial Review. All final administrative decisions of the Board of Adjustment shall be subject to judicial review pursuant to the provision of Chapter 414 of the *Code of Iowa*, 1981, and all amendments and modifications thereof, and the rules adopted pursuant thereto.

165.36 DISTRICT CHANGES AND ZONING CODE AMENDMENTS.

1. Zoning Commission Approval. In accordance with the provisions of Chapter 414 of the *Code of Iowa*, the Council may, from time to time amend or change by ordinance the number, shape, or area of districts established on the Official Zoning Map or the regulations set forth in the Zoning Code; but no such amendment or change shall become effective unless the ordinance proposing such amendment or change shall first be submitted to the Planning and Zoning Commission for approval, disapproval, or suggestions, and said Planning and Zoning Commission shall have been allowed a reasonable time, not less than 30 days, for consideration and report.

2. Hearings on Changes, Notice. Before submitting its recommendations and report to the Council, the Planning and Zoning Commission shall hold a public hearing on the proposed amendment, supplement, or change. It shall give not less than 15 nor more than 30 days' notice of the time and place of such hearing by publication in a newspaper published in the community and by mailing notices to all property owners directly involved, contiguous to, or directly across a street or alley from the area proposed to be altered.

3. Amendment Petition. Any person desiring a change in zoning or property may make application therefor, and in so doing shall accompany the petition for such change in zoning, or the ordinance introduced for the purpose of changing such zoning, with a fee in the amount of \$50.00 towards the cost of processing the application. Should the application be withdrawn prior to publication of legal notice thereon, such fee will be returned upon written request of the applicant.

4. Public Filing Vote. During the 15 days prior to the public hearing, the text or copy of the text of such ordinance or petition, together with the maps or plans or copies

thereof shall be on file, for public examination, in the office of the Clerk, or City Hall. No ordinance which differs from the recommendations made by the Planning and Zoning Commission shall become effective unless passed by not less than three-fourths of all members of the Council.

5. Protest. In case of a written protest against a proposed change in the boundaries of a district signed and acknowledged by the owners of 20 percent or more of either the frontage proposed to be altered, or of the frontage immediately adjoining or across an alley therefrom, or directly opposite the frontage proposed to be altered, is filed with the Clerk, such amendment shall not be passed or become effective except by the favorable vote of three-fourths of all members of the Council.

6. Procedural Omissions. The failure to notify, as provided by this section, shall not invalidate an ordinance, provided such failure was not intentional, and the omission of the name of any owner or occupant of property who may, in the opinion of the Zoning Commission, be affected by such amendment, supplement or change, unless such omission is intentional, shall not invalidate any ordinance passed hereunder, it being the intention of the section to provide so far as may be for notice to the persons substantially interested in the proposed change that an ordinance is pending before the Council, proposing to make a change in zoning.

165.37 PENALTY.

1. In case any building or structure is erected, constructed, reconstructed, altered, repaired, converted, or maintained, or any building, structure, or land used in violation of the provisions of the regulations, the City Attorney, in addition to other remedies under the *Code of Iowa*, is hereby authorized to institute an action to enjoin, or any other appropriate action or proceeding to prevent such erection, construction, reconstruction, alteration, repair, conversion, maintenance, or use.

2. Any person, firm, or corporation who violates, disobeys, omits, neglects, or refuses to comply with any of the provisions of the regulations shall, upon conviction, be fined not less than \$50.00 nor more than \$200.00 for each offense. Each day that a violation continues shall constitute a separate offense and the City Attorney is hereby authorized to prosecute all violations referred to in this section.

INDEX TO CODE OF ORDINANCES

CHAPTER OR SECTION NUMBER

ABANDONED BUILDINGS	145
ABANDONED OR UNATTENDED REFRIGERATORS	41.08
ABANDONED UTILITY CONNECTIONS	
On-Site Wastewater Treatment and Disposal Systems	98.07
Sanitary Sewer Service	95.10
Water Service	90.04
ABANDONED VEHICLES	80
<i>See also</i> Impounding Vehicles	70.06
<i>See also</i> State Code Traffic Regulations.....	62.01
ABANDONMENT OF CATS AND DOGS	55.04
ABATEMENT OF NUISANCES	50
ACCESSORY BUILDINGS	165.13
ACCOUNTING RECORDS	7.07
AIR POLLUTION	50.02(8)
<i>See also</i> ENVIRONMENTAL VIOLATION	3.02
ALCOHOL	
Consumption and Intoxication	45
Liquor Licenses and Wine and Beer Permits	120
Open Containers in Motor Vehicles.....	62.01(50) and (51)
Social Host Liability	45.04
ALL-TERRAIN VEHICLES AND SNOWMOBILES	75
AMUSEMENT DEVICES	120.06
ANGLE PARKING	69.03 and 69.04
ANIMAL PROTECTION AND CONTROL	
Abandonment of Cats and Dogs.....	55.04
Animal Neglect.....	55.02
Annoyance or Disturbance	55.08
At Large Prohibited	55.06
Confinement	55.12
Damage or Interference by Animals.....	55.07
Dangerous and Vicious Animals	57
Duty to Report Attacks.....	55.11
Impounding.....	55.13 - 55.15
Livestock.....	55.03 and 55.05
Pet Awards Prohibited	55.16
Rabies Vaccination.....	55.10

	CHAPTER OR SECTION NUMBER
ANIMAL PROTECTION AND CONTROL (CONTINUED)	
Tampering with a Rabies Vaccination Tag	55.17
Tampering with an Electronic Handling Device	55.18
Vicious Dogs.....	55.09
ANTENNA AND RADIO WIRES	41.09
APPOINTMENTS	
By Council.....	17.05
By Mayor.....	15.03
ASSAULT	40.01
ATTORNEY FOR CITY.....	20
ATVS, UTVS, AND SNOWMOBILES	75
AUTOMOBILE REPAIR ON PUBLIC PROPERTY.....	69.05(2)
BARBED WIRE AND ELECTRIC FENCES.....	41.10
BEER, LIQUOR, AND WINE CONTROL	
<i>See ALCOHOL</i>	
BICYCLES	
<i>See also</i> Clinging to Vehicles	62.04
<i>See also</i> State Code Traffic Regulations.....	62.01
BILLBOARDS.....	50.02(6) and 62.06
BOARDS AND COMMISSIONS	
Board of Adjustment.....	165.35
Library Board.....	22
Planning and Zoning Commission.....	23
BONDS	
City Officials	5.02
House Movers.....	123.04
Public Bonds, Records of.....	18.08(3)
Streets	135.09(4)
BUDGET	
Amendments.....	7.06
Preparation.....	7.05
BUILDING MOVERS.....	123
BUILDING NUMBERING	150
BUILDING SEWERS AND CONNECTIONS	96
BUILDINGS, DANGEROUS.....	145
BULKY RUBBISH.....	106.05

	CHAPTER OR SECTION NUMBER
BURNING	
Burning on Streets and Alleys	135.08
Fires or Fuel on Sidewalks.....	136.14
Junk Dealers.....	124.10(5)
Open Burning Restricted	105.05
Yard Waste.....	105.06
BUSINESS DISTRICT	60.02(1)
<i>See also:</i>	
Sidewalks	136.08(5)(B)
CAR WASHING ON STREETS	135.07
CHANGE FUND	7.03(3)
CHARTER	2
CIGARETTES AND TOBACCO	
Permits	121
Possession by Minors	46.02
CITY ATTORNEY	20
CITY CHARTER	2
CITY CLERK	18
CITY COUNCIL	
Appointments by.....	17.05
Compensation	17.06
Meetings.....	17.04 and 5.06
Number and Term	2.04 and 17.01
Powers and Duties.....	17.02 and 17.03
CITY ELECTIONS	6
CITY OFFICERS AND EMPLOYEES	
Appointments by Council.....	17.05
Appointments by Mayor.....	15.03
Bonds.....	5.02
City Attorney.....	20
City Clerk.....	18
City Council	17
City Treasurer.....	19
Conflict of Interest.....	5.07
Discretionary Powers.....	1.13
Extension of Authority	1.07
Gifts to	5.11
Harassment of	41.05
Indemnity of	1.04
Mayor.....	15
Oath of Office.....	5.01

CHAPTER OR SECTION
NUMBER

CITY OFFICERS AND EMPLOYEES (CONTINUED)

 Powers and Duties..... 5.03

 Removal of an Officer’s Communication or Control Device 41.07

 Removal of Appointed Officers and Employees..... 5.09

 Resignations..... 5.08

 Sewer Superintendent..... 95.03

 Vacancies..... 5.10

 Water Superintendent..... 90.02

CITY OPERATING PROCEDURES 5

CITY POWERS..... 1.03

CITY SEAL 18.13

CIVIL CITATIONS 3.04

CLINGING TO VEHICLE..... 62.04

CODE OF IOWA TRAFFIC REGULATIONS..... 62.01

CODE OF ORDINANCES

 Altering..... 1.10

 Amendments to..... 1.08

 Catchlines and Notes..... 1.09

 Definitions of Terms..... 1.02

 Rules of Construction 1.06

 Validity 1.11

COMPENSATION

 Changes in 17.02(6)

 City Attorney 20.01

 City Clerk..... 18.01

 Council Members..... 17.06

 Mayor 15.04

 Mayor Pro Tem 16.04

 Set by Council..... 17.02(6)

 Treasurer..... 19.02

CONFLICT OF INTEREST 5.07

CONTRACT LAW ENFORCEMENT 30

CONTRIBUTING TO DELINQUENCY 46.03

COUNCIL..... 17

COUNCIL MEETINGS 17.04

CRIMINAL MISCHIEF..... 42.02

	CHAPTER OR SECTION NUMBER
CROSSWALKS	
Designation and Maintenance.....	61.02
Parking Prohibited in	69.06(1)
Pedestrians in Crosswalks.....	65.05
CURFEW	46.01
DANGEROUS BUILDINGS	145
DANGEROUS SUBSTANCES, DISTRIBUTING OF	41.01
DANGEROUS TOYS (THROWING AND SHOOTING)	41.12
DANGEROUS AND VICIOUS ANIMALS	57
DEFACING PROCLAMATIONS AND NOTICES	42.03
DEPOSIT FOR UTILITIES	92.09
DEPOSITS AND INVESTMENTS	7.03(2)
DESTRUCTION OF PROPERTY	42.02
DISCRETIONARY POWER OF CITY OFFICERS AND EMPLOYEES	1.13
DISORDERLY CONDUCT	40.03
DOGS	55
<i>See also ANIMALS</i>	
DRUG PARAPHERNALIA	41.15
DUTCH ELM DISEASE	50.02(10)
EASEMENTS, USE OF	95.08
ELECTIONS	
Duties of Clerk.....	18.12
Procedures.....	6
ELECTRIC FRANCHISE	111
ENVIRONMENTAL VIOLATIONS	3.02
EXCAVATIONS	
Natural Gas Franchise	110.05
Sewer	96.04
Streets.....	135.09
Water.....	90.09
EXTENSION OF AUTHORITY	1.07
FAILURE TO ASSIST	41.16
FAILURE TO DISPERSE	40.04
FALSE IDENTIFICATION INFORMATION	41.03

	CHAPTER OR SECTION NUMBER
FALSE REPORTS	
Of Catastrophe.....	40.03(5)
To Public Safety Entities.....	41.02
FENCES	
Barbed Wire and Electric Fences.....	41.10
Blocking Public and Private Ways.....	50.02(5)
Junk Dealers.....	124.10(4)
Zoning.....	165.33(4)(F) and (5)(C)
FIGHTING	40.03(1)
FINANCE OFFICER	7.02
FINANCES	7
FINANCIAL REPORTS	7.08
FIRE HAZARD CONDITIONS	
Health and Fire Hazard.....	105.04
Storing of Flammable Junk.....	50.02(7)
Unsafe Buildings.....	145
Weeds and Brush.....	50.02(9)
FIRE SPRINKLER SYSTEMS CONNECTIONS	91.03
FIRES	
On Sidewalks.....	136.14
Open Burning Restricted.....	105.05
FIREWORKS	41.14
FISCAL MANAGEMENT	7
FLAG, DISRESPECT OF	40.03(6)
FORM OF GOVERNMENT	2.02
FRAUD	42.05
FUNDS	7.04
FUNERAL SERVICE, DISRUPTION OF	40.03(7)
<i>See also</i> State Code Traffic Regulations.....	62.01
GANG ACTIVITY	50.02(11)
GARAGES	165.30
GARBAGE COLLECTION AND DISPOSAL	105 and 106
GAS FRANCHISE	110
GIFTS TO CITY OFFICIALS	5.11

	CHAPTER OR SECTION NUMBER
GOLF CARTS	78
GRADES OF STREETS, ALLEYS, AND SIDEWALKS	138
HANDICAPPED PARKING	
<i>See</i> Persons with Disabilities Parking	69.07
HARASSMENT	
Of Other Persons	40.02
Of Public Officers and Employees	41.05
HAZARDOUS WASTE	105.08
<i>See also</i> Prohibited and Restricted Discharges to Sewer System	97.03 and 97.04
HITCHHIKING	67.02
HOUSE MOVERS	123
HOUSE NUMBERS	150
HOUSES OF ILL FAME	50.02(11)
IMPOUNDING	
Animals	55.13
Vehicles	70.06 and 80.02
INDEMNITY AGREEMENT, PERMITS, AND LICENSES	1.04
INSPECTIONS	
Building Sewers and Connections	96.08
Junk Dealers	124.10(2)
Sanitary Sewer System	95.03(2)
Street Use and Maintenance	135.09(7)
Trees	151.06
Water Service System	90.16
INSURANCE REQUIREMENTS	
Fireworks	41.14
House Movers	123.05
Street Excavations	135.09(5)
INTERFERENCE WITH OFFICIAL ACTS	41.06
INVESTMENTS AND DEPOSITS	7.03(2)
JUNK AND JUNK VEHICLES	51
<i>See also</i> Storing of Flammable Junk	50.02(7)
JUNK DEALERS	124
LEGAL OPINIONS	20.06
LIBRARY	22

	CHAPTER OR SECTION NUMBER
LICENSES	
Drivers	62.01
Liquor	120
Peddlers, Solicitors, and Transient Merchants	122
<i>See also</i> Issuance of Licenses and Permits	18.10
<i>See also</i> Permits	
LIQUOR LICENSES AND WINE AND BEER PERMITS	120
LITTERING	
Debris on Sidewalks.....	136.16
Placing Debris on Streets.....	135.03
Solid Waste Control	105.07
LIVESTOCK	55.03 and 55.05
LOAD AND WEIGHT RESTRICTIONS, VEHICLES	66
MANUFACTURED AND MOBILE HOMES	146
<i>See also:</i>	
Mobile Homes (Zoning Regulations).....	165.26
MAYOR	
Appointments.....	15.03
Compensation	15.04
Powers and Duties.....	15.02
Term of Office.....	15.01
Voting.....	15.05
<i>See also</i> City Officers And Employees	
MAYOR PRO TEM	16
MEETINGS	
Council Meetings	17.04
Procedures for Notice and Conduct of.....	5.06
Publication of Minutes of Council Meetings	18.03
METERS, WATER.....	91
MINORS	46
<i>See also:</i>	
Amusement Devices	120.06
Employment for Serving of Alcohol.....	120.05(4)
Persons Under Legal Age (Alcohol).....	45.01
Persons Under Legal Age (Tobacco)	121.07
MOBILE HOMES	146
<i>See also</i> Zoning Regulations	165.26
MOWING	53

	CHAPTER OR SECTION NUMBER
MUNICIPAL INFRACTIONS	3
<i>See also</i> Municipal Infraction Abatement Procedure	50.07
NAMING OF STREETS	139
NATURAL GAS FRANCHISE	110
NOISE	
Annoyance or Disturbance (Barking Dogs)	55.08
Disorderly Conduct	40.03(2)
Quiet Zones	62.05
Truck Parking.....	69.09(2)
NOMINATIONS FOR ELECTIVE OFFICES	6
NUISANCE ABATEMENT PROCEDURE	50
NUMBERING OF BUILDINGS	150
OATH OF OFFICE	5.01
OFFENSIVE SMELLS AND SUBSTANCES	50.02(1) and (2)
<i>See also</i> Restricted Discharges to Sanitary Sewer System	97.04
OFF-ROAD MOTORCYCLES AND UTILITY VEHICLES	75
ONE-WAY TRAFFIC	68
ON-SITE WASTEWATER SYSTEMS	98
OPEN BURNING	105.05
OPEN CONTAINERS IN MOTOR VEHICLES	62.01(50) and (51)
OPEN MEETINGS	5.06
OPERATING PROCEDURES	5
PARADES REGULATED	60.08
PARKING REGULATIONS	
All Night Parking Prohibited	69.08
Angle Parking.....	69.03 and 69.04
Illegal Purposes	69.05
Park Adjacent to Curb	69.02
Parking Limited or Controlled	69.01
Parking Prohibited	69.06
Parking Violations	70.03 and 70.04
Persons With Disabilities Parking	69.07
Snow and Ice.....	69.10
Snow Routes	69.11
Truck Parking Limited	69.09

	CHAPTER OR SECTION NUMBER
PEACE OFFICERS	
Failure to Assist.....	41.04
Interference with.....	41.06
Obedience to.....	60.07
Powers and Authority under Traffic Code	60
Removal of an Officer's Communication or Control Device	41.07
PEDDLERS, SOLICITORS, AND TRANSIENT MERCHANTS	122
PEDESTRIANS	67
<i>See also:</i>	
Crosswalks.....	61.02
State Code Traffic Regulations.....	62.01
Yield to Pedestrians in Crosswalks.....	65.05
PENALTIES	
Cigarette and Tobacco Permits	121.07
Curfew Violations.....	46.01(6)
Mowing.....	53.04
Municipal Infractions.....	3
Rental Permit Process.....	148.02(3)
Sanitary Sewer Regulations	95.09
Sewer Connection Requirements.....	96.10
Standard Penalty for Violation of Code of Ordinances	1.14
Traffic Code Violations	70
PERMITS	
Beer and Wine	120
Building.....	165.21
Cigarette and Tobacco.....	121.02
House Mover	123.02
On-Site Wastewater System.....	98.04
Parade	60.08(1)
Persons with Disabilities Parking.....	69.07
Rental Permit.....	148
Sewer Connection	96.01
Sidewalks.....	136.07
Street Excavation	135.09(1)
Vehicles, Excess Size and Weight.....	66.02
Vending Machines and Sales Stands on Sidewalks.....	136.18
Water System Connection	90.05
<i>See also</i> Issuance of Licenses and Permits.....	18.10
<i>See also</i> Licenses	
PERSONAL INJURIES	1.05
PET AWARDS PROHIBITED	55.16

	CHAPTER OR SECTION NUMBER
PLANNING AND ZONING COMMISSION	23
PLAY STREETS	62.02
<i>See also</i> Playing in Streets	135.04
POLLUTION	
Air Pollution	50.02(8)
Environmental Violations.....	3.02
Incinerators Required	105.10(3)
Open Burning Restricted	105.05
Prohibited Discharges to Public Sewer.....	97.03
Restricted Discharges to Sewer System.....	97.04
Toxic and Hazardous Wastes	105.08
Water Pollution.....	50.02(4)
POWERS AND DUTIES	
City Clerk.....	18.02
City Council	17.02 and 17.03
City Officers Generally	2.03
City Treasurer.....	19.03
Mayor.....	15.02
Mayor Pro Tem	16.02
Municipal Officers	5.03
PRIVATE PROPERTY	42
PRIVATE WATER SYSTEMS (SEWER CHARGES)	99.03
PROPERTY MAINTENANCE CODE	147
PUBLIC AND PRIVATE PROPERTY	
Criminal Mischief.....	42.02
Damage to Sewer System	95.04(1)
Defacing Proclamations or Notices.....	42.03
Fraud.....	42.05
Injury to Library Books or Property	22.10
Littering Prohibited.....	105.07
Public and Private Property	42
Sidewalk Regulations	136
Street Excavations	135
Theft	42.06
Trees and Shrubs on Public Property	151
Trespassing.....	42.01
Unauthorized Entry	42.04
PUBLIC HEALTH AND SAFETY	41
PUBLIC NOTICES	18.05(1)

	CHAPTER OR SECTION NUMBER
PUBLIC OFFENSES	
Drug Paraphernalia.....	41.15
Littering Prohibited.....	105.07
Public and Private Property	42
Public Health and Safety	41
Public Peace.....	40
<i>See also</i> Sidewalk Regulations	136
<i>See also</i> Street Excavations	135
PUBLICATION REQUIREMENTS.....	18.05
RABIES VACCINATION	55.10
RECORDS	
Accounting.....	7.07
Maintenance by Clerk	18.08
Minutes of Council Meetings	5.06(3)
Public Records, Access to	5.04
Transfer to Successors	5.05
REMOVAL OF APPOINTED OFFICERS AND EMPLOYEES.....	5.09
RENTAL PERMIT PROCESS.....	148
RESIGNATION OF ELECTED OFFICERS	5.08
RIGHT TO ENTER	
Sewer Service Inspection and Sampling.....	95.07
Solid Waste Collection	106.06
Use of Easements.....	95.08
Warrants.....	1.12
Water Meter Service.....	91.08
SANITARY SEWER SYSTEM	
Building Sewers and Connection Requirements	96
General Provisions	95
On-Site Wastewater Systems	98
Sewer Service Charges	99
Use of Public Sewers	97
SEWER RATES.....	99
SIDEWALKS	
Barricades and Warning Lights.....	136.09
Construction Standards	136.08
Debris on	136.16
Defacing	136.15
Encroaching Steps.....	136.12
Fires and Fuel on.....	136.14
Interference with Improvements	136.11
Maintenance.....	136
Openings and Enclosures	136.13

	CHAPTER OR SECTION NUMBER
SIDEWALKS (CONTINUED)	
Parking Prohibited on Sidewalks	69.06(4)
Sales Stands and Merchandise Displays	136.17 and 136.18
Snow Removal.....	136.03
Vehicles on Sidewalks.....	62.03
SKATES, COASTERS, AND TOY VEHICLES	
Clinging to Vehicle	62.04 and 79
SNOW REMOVAL	
From Sidewalks.....	136.03
From Streets	135.12
SNOW ROUTES.....	69.11
SNOWMOBILES, ATVS, AND UTVS.....	75
SOLICITORS, PEDDLERS, AND TRANSIENT MERCHANTS.....	122
SOLID WASTE CONTROL	
Collection.....	106
General Provisions	105
<i>See also</i> Restricted Discharges to Sewer System.....	97.04
SPEED REGULATIONS.....	63
STATE CODE TRAFFIC REGULATIONS.....	62.01
STOP OR YIELD REQUIRED.....	65
STORMWATER	
Discharge to Sanitary Sewer Prohibited	95.04(2) and 97.01
Surface Water Exception.....	97.02
STREET NAME MAP.....	139.04 and 139.05
STREETS AND ALLEYS	
Billboards and Signs Obstructing View.....	50.02(6)
Blocking Public and Private Ways.....	50.02(5)
Excavations and Maintenance	135
Grades.....	138
Naming.....	139
Vacation and Disposal.....	137
<i>See also</i> Traffic Code	
TERMS OF OFFICE	
Clerk	18.01
Council.....	2.04 and 17.01
Mayor.....	2.05 and 15.01
Treasurer.....	19.01

	CHAPTER OR SECTION NUMBER
THEFT	
Library Property	22.11
Public and Private Property	42.06
TOBACCO PERMITS	121
TOXIC AND HAZARDOUS WASTE	105.08
TRAFFIC CODE	
Administration of	60
Enforcement Procedures	70
General Regulations	62
Load and Weight Restrictions	66
One-Way Traffic	68
Parking Regulations	69
Pedestrians	67
Speed Regulations	63
Stop or Yield Required	65
Traffic Control Devices	61
Turning Regulations	64
TRAFFIC CONTROL DEVICES	
Installation; Standards; Compliance	61
Traveling on Barricaded Street or Alley	135.05
TRAFFIC REGULATIONS	62.01
TRANSIENT MERCHANTS, PEDDLERS, AND SOLICITORS	122
TREASURER	19
TREES	
Disease Control	151.05
Dutch Elm Disease	50.02(10)
Duty to Trim Trees	151.03
Inspection and Removal of	151.06
Maintenance of Parking or Terrace	135.10
Obstructing View at Intersections	62.06
Open Burning Restrictions	105.05
Planting Restrictions	151.02
Trimming Trees to be Supervised	151.04
Yard Waste	105.06
TRESPASSING	42.01
TRUCK PARKING LIMITED	69.09
TRUCK ROUTES	66.05
TURNING REGULATIONS	64

	CHAPTER OR SECTION NUMBER
URBAN CHICKENS	56
UNAUTHORIZED ENTRY	42.04
URBAN REVITALIZATION AREA	11
URINATING AND DEFECATING IN PUBLIC	41.13
UTILITIES	
Electric	111
Natural Gas	110
Sewer Service System.....	95 - 99
Water Service System.....	90 - 93
U-TURNS	64.02
UTVS, ATVS, AND SNOWMOBILES	75
VACANCIES IN OFFICE	5.10
VACATING STREETS OR ALLEYS	137
VETO	
Council May Override.....	17.03
Mayor’s Authority.....	15.02(4)
VICIOUS DOGS	55.09
VIOLATIONS	
Cigarette and Tobacco Violations (Sale to Minors).....	121.07
Environmental.....	3.02
Municipal Infractions	3
Parking.....	70
Special Penalties for Violation of Sanitary Sewer Regulations.....	95.09
Standard Penalty for Violation of Code of Ordinances	1.14
Traffic.....	62.01
Zoning.....	165.37
WARRANTS	1.12
WASTE STORAGE CONTAINERS	105.09
WASTEWATER SYSTEMS, ON-SITE	98
WATER POLLUTION	50.02(4)
WATER SERVICE SYSTEM	
Connections; General Regulations.....	90
Meters	91
Rates	92
Well Protection.....	93

	CHAPTER OR SECTION NUMBER
WEAPONS	
Discharging Weapons in City Limits	41.11
Throwing and Shooting	41.12
WEEDS AND BRUSH	50.02(9)
WINE	
<i>See</i> Alcohol	
YARD REQUIREMENTS	
<i>See</i> Zoning	165.22 - 165.26
YARD WASTE	105.06
YIELD REQUIRED	65
ZONING REGULATIONS	165

APPENDIX TO CODE OF ORDINANCES

USE AND MAINTENANCE OF THE CODE OF ORDINANCES

The following information is provided to assist in the use and proper maintenance of this Code of Ordinances.

DISTRIBUTION OF COPIES

1. **OFFICIAL COPY.** The “OFFICIAL COPY” of the Code of Ordinances must be kept by the City Clerk and should be identified as the “OFFICIAL COPY.”

2. **DISTRIBUTION.** Other copies of the Code of Ordinances should be made available to all persons having a relatively frequent and continuing need to have access to ordinances which are in effect in the City as well as reference centers such as the City Library, County Law Library, and perhaps the schools.

3. **SALE.** The sale or distribution of copies in a general fashion is not recommended as experience indicates that indiscriminate distribution tends to result in outdated codes being used or misused.

4. **RECORD OF DISTRIBUTION.** The City Clerk should be responsible for maintaining an accurate and current record of persons having a copy of the Code of Ordinances. Each official, elected or appointed, should return to the City, upon leaving office, all documents, records and other materials pertaining to the office, including this Code of Ordinances.

(Code of Iowa, Sec. 372.13[4])

NUMBERING OF ORDINANCES AMENDING THE CODE OF ORDINANCES

It is recommended that a simple numerical sequence be used in assigning ordinance numbers to ordinances as they are passed. For example, if the ordinance adopting the Code of Ordinances is No. 163, we would suggest that the first ordinance passed changing, adding to, or deleting from the Code be assigned the number 164, the next ordinance be assigned the number 165, and so on. We advise against using the Code of Ordinances numbering system for the numbering of ordinances.

RETENTION OF AMENDING ORDINANCES

Please note that two books should be maintained: (1) the Code of Ordinances; and (2) an ordinance book. We will assist in the maintenance of the Code of Ordinances book, per the Supplement Agreement, by revising and returning appropriate pages for the Code of Ordinances book as required to accommodate ordinances amending the Code. The City Clerk is responsible for maintaining the ordinance book and must be sure that an original copy of each ordinance adopted, bearing the signatures of the Mayor and Clerk, is inserted in the ordinance book and preserved in a safe place.

SUPPLEMENT RECORD

A record of all supplements prepared for the Code of Ordinances is provided in the front of the Code. This record will indicate the number and date of the ordinances adopting the original Code and of each subsequently adopted ordinance which has been incorporated in the Code. For each supplemented ordinance, the Supplement Record will list the ordinance number, date, topic, and chapter or section number of the Code affected by the amending ordinance. A periodic review of the Supplement Record and ordinances passed will assure that all ordinances amending the Code have been incorporated therein.

DISTRIBUTION OF SUPPLEMENTS

Supplements containing revised pages for insertion in each Code will be sent to the Clerk. It is the responsibility of the Clerk to see that each person having a Code of Ordinances receives each supplement so that each Code may be properly updated to reflect action of the Council in amending the Code.

AMENDING THE CODE OF ORDINANCES

The Code of Ordinances contains most of the laws of the City as of the date of its adoption and is continually subject to amendment to reflect changing policies of the Council, mandates of the State, or decisions of the Courts. Amendments to the Code of Ordinances can only be accomplished by the adoption of an ordinance.

(Code of Iowa, Sec. 380.2)

The following forms of ordinances are recommended for making amendments to the Code of Ordinances:

ADDITION OF NEW PROVISIONS

New material may require the addition of a new SUBSECTION, SECTION or CHAPTER, as shown in the following sample ordinance:

ORDINANCE NO. ____

AN ORDINANCE AMENDING THE CODE OF ORDINANCES OF THE CITY OF _____, IOWA, BY ADDING A NEW SECTION LIMITING PARKING TO 30 MINUTES ON A PORTION OF _____ STREET

BE IT ENACTED by the City Council of the City of _____, Iowa:

SECTION 1. NEW SECTION. The Code of Ordinances of the City of _____, Iowa, is amended by adding a new Section 69.16, entitled PARKING LIMITED TO 30 MINUTES, which is hereby adopted to read as follows:

69.16 PARKING LIMITED TO 30 MINUTES. It is unlawful to park any vehicle for a continuous period of more than 30 minutes between the hours of 8:00 a.m. and 8:00 p.m. on each day upon the following designated streets:

- 1. _____ Street, on the _____ side, from _____ Street to _____ Street.

SECTION 2. REPEALER. All ordinances or parts of ordinances in conflict with the provisions of this ordinance are hereby repealed.

SECTION 3. SEVERABILITY CLAUSE. If any section, provision, or part of this ordinance shall be adjudged invalid or unconstitutional, such adjudication shall not affect the validity of the ordinance as a whole or any section, provision, or part thereof not adjudged invalid or unconstitutional.

SECTION 4. WHEN EFFECTIVE. This ordinance shall be in effect from and after its final passage, approval, and publication as provided by law.

Passed by the Council the ____ day of _____, 20 ____, and approved this ____ day of _____, 20 ____.

Mayor

ATTEST:

City Clerk

First Reading: _____

Second Reading: _____

Third Reading: _____

I certify that the foregoing was published as Ordinance No. _____ on the ____ day of _____, 20 ____.

City Clerk

DELETION OF EXISTING PROVISIONS

Provisions may be removed from the Code of Ordinances by deleting SUBSECTIONS, SECTIONS or CHAPTERS, as shown in the following sample ordinance:

ORDINANCE NO. ____

AN ORDINANCE AMENDING THE CODE OF ORDINANCES OF THE CITY OF _____, IOWA, BY REPEALING SECTION 65.02, SUBSECTION 5, PERTAINING TO THE SPECIAL STOP REQUIRED ON _____ STREET.

BE IT ENACTED by the City Council of the City of _____, Iowa:

SECTION 1. SUBSECTION REPEALED. The Code of Ordinances of the City of _____, Iowa, is hereby amended by repealing Section 65.02, Subsection 5, which required vehicles traveling south on _____ Street to stop at _____ Street.

SECTION 2. SEVERABILITY CLAUSE. If any section, provision, or part of this ordinance shall be adjudged invalid or unconstitutional, such adjudication shall not affect the validity of the ordinance as a whole or any section, provision, or part thereof not adjudged invalid or unconstitutional.

SECTION 3. WHEN EFFECTIVE. This ordinance shall be in effect from and after its final passage, approval, and publication as provided by law.

Passed by the Council the ____ day of _____, 20____, and approved this ____ day of _____, 20____.

Mayor

ATTEST:

City Clerk

First Reading: _____

Second Reading: _____

Third Reading: _____

I certify that the foregoing was published as Ordinance No. ____ on the ____ day of _____, 20____.

City Clerk

MODIFICATION OR CHANGE OF EXISTING PROVISION

Existing provisions may be added to, partially deleted, or changed, as shown in the following sample:

ORDINANCE NO. ____

AN ORDINANCE AMENDING THE CODE OF ORDINANCES OF THE CITY OF _____, IOWA, BY AMENDING PROVISIONS PERTAINING TO SEWER SERVICE CHARGES

BE IT ENACTED by the City Council of the City of _____, Iowa:

SECTION 1. SECTION MODIFIED. Section 99.01 of the Code of Ordinances of the City of _____, Iowa, is repealed and the following adopted in lieu thereof:

99.01 SEWER SERVICE CHARGES REQUIRED. Every customer shall pay to the City sewer service charges in the amount of _____ percent of the bill for water and water service attributable to the customer for the property served, but in no event less than \$ _____ dollars per _____.

SECTION 2. SEVERABILITY CLAUSE. If any section, provision, or part of this ordinance shall be adjudged invalid or unconstitutional, such adjudication shall not affect the validity of the ordinance as a whole or any section, provision, or part thereof not adjudged invalid or unconstitutional.

SECTION 3. WHEN EFFECTIVE. This ordinance shall be in effect from and after its final passage, approval, and publication as provided by law.

Passed by the Council the ____ day of _____, 20____, and approved this ____ day of _____, 20____.

Mayor

ATTEST:

City Clerk

First Reading: _____

Second Reading: _____

Third Reading: _____

I certify that the foregoing was published as Ordinance No. _____ on the ____ day of _____, 20____.

City Clerk

ORDINANCES NOT CONTAINED IN THE CODE OF ORDINANCES

There are certain types of ordinances which the City will be adopting which do not have to be incorporated in the Code of Ordinances. These include ordinances: (1) establishing grades of streets or sidewalks; (2) vacating streets or alleys; (3) authorizing the issuance of bonds; and (4) amending the zoning map.

(Code of Iowa, Sec. 380.8)

ORDINANCE NO. ____

AN ORDINANCE VACATING (INSERT LOCATION OR LEGAL DESCRIPTION OF STREET OR ALLEY BEING VACATED) TO _____, IOWA

Be It Enacted by the City Council of the City of _____, Iowa:

SECTION 1. The (location or legal description of street or alley) to _____, Iowa, is hereby vacated and closed from public use.

SECTION 2. The Council may by resolution convey the alley described above to abutting property owners in a manner directed by the City Council.

SECTION 3. All ordinances or parts of ordinances in conflict with the provisions of this ordinance are hereby repealed.

SECTION 4. If any section, provision, or part of this ordinance shall be adjudged invalid or unconstitutional, such adjudication shall not affect the validity of the ordinance as a whole or any section, provision, or part thereof not adjudged invalid or unconstitutional.

SECTION 5. This ordinance shall be in effect from and after its final passage, approval, and publication as provided by law.

Passed by the Council the ___ day of _____, 20___, and approved this ___ day of _____, 20___.

Mayor

ATTEST:

City Clerk

First Reading: _____

Second Reading: _____

Third Reading: _____

I certify that the foregoing was published as Ordinance No. ____ on the ___ day of _____, 20___.

City Clerk

These ordinances should be numbered in the same numerical sequence as any other amending ordinance and placed in their proper sequence in the ordinance book.

SUGGESTED FORMS

FIRST NOTICE – DANGEROUS BUILDING

TO: (Name and address of owner, agent, or occupant of the property on which nuisance is located or the person causing or maintaining the nuisance).

You are hereby notified to abate the nuisance existing at (name location of nuisance) within ___ days from service of this notice or file written request for a Council hearing with the undersigned officer within said time limit.

The nuisance consists of (describe the nuisance and cite the law or ordinance) and shall be abated by (state action necessary to abate the particular nuisance).

In the event you fail to abate or cause to be abated the above nuisance, as directed, or file written request for hearing within the time prescribed herein, the City will take such steps as are necessary to abate or cause to be abated the nuisance and the cost will be assessed against you as provided by law.

Date of Notice: _____

City of _____, Iowa

By: _____
(enforcement officer)

NOTICE OF HEARING ON DANGEROUS BUILDING

TO: (Name and address of the owner, agent, or occupant of the property on which nuisance is located or the person causing or maintaining the nuisance).

You are hereby notified that the City Council of _____, Iowa, will meet on the ___ day of _____, 20 __, at _____ p.m., in the Council Chambers of the City Hall, at (address of City Hall) for the purpose of considering whether or not the alleged nuisance consisting of (describe the nuisance) on your property, locally known as _____, constitutes a nuisance pursuant to Chapter _____ of the Code of Ordinances of _____, Iowa, and should be abated by (state action necessary to abate the particular nuisance).

You are further notified that at such time and place you may appear and show cause why the said alleged nuisance should not be abated.

You are further notified to govern yourselves accordingly.

Date of Notice: _____

City of _____, Iowa

By: _____
(enforcement officer)

**RESOLUTION AND ORDER
REGARDING DANGEROUS BUILDING**

BE IT RESOLVED, by the City Council of the City of _____, Iowa:

WHEREAS, notice has heretofore been served on the ___ day of _____, 20___, on (property owner’s name), through (agent’s name or “none”), agent, to abate the nuisance existing at (legal description and address) within ___ days from service of said notice upon the said (name of owner or agent). and

(EITHER)

WHEREAS, a hearing was requested by the said (name of property owner or agent) and the same was held at this meeting and evidence produced and considered by the City Council.

(OR, ALTERNATE TO PRECEDING PARAGRAPH)

WHEREAS, the said owner (agent) named above has failed to abate or cause to be abated the above nuisance as directed within the time set, and after evidence was duly produced and considered at this meeting, and said owner has failed to file a written request for hearing, as provided, after being properly served by a notice to abate.

NOW THEREFORE, BE IT RESOLVED that the owner of said property, or said owner’s agent (name of owner or agent) is hereby directed and ordered to abate the nuisance consisting of (describe the nuisance) by (state action necessary to abate) within ___ days after the service of this Order upon said owner or agent. and

BE IT FURTHER RESOLVED that the enforcement officer be and is hereby directed to serve a copy of this Order upon the said property owner or agent named above. and

BE IT FURTHER RESOLVED that in the event the owner, or agent (name the owner or agent) fails to abate the said nuisance within the time prescribed above, then and in that event the City will abate the said nuisance and the cost will be assessed against the property or owner (owner’s name) at (address), as the law shall provide.

Moved by _____ to adopt.

Adopted this ___ day of _____, 20___.

Mayor

ATTEST:

City Clerk

Note: It is suggested by the blank space in the resolution that additional time be allowed the owner to abate the nuisance after the passage of the resolution before any action is taken on the part of the City to abate the same. In some instances, for the sake of public safety, the time element could be stricken from the resolution and immediate action be taken to abate the nuisance after the order is given.

NOTICE TO ABATE NUISANCE

TO: (Name and address of owner, agent, or occupant of the property on which the nuisance is located or the person causing or maintaining the nuisance).

You are hereby notified to abate the nuisance existing at (name location of nuisance) or file written request for a hearing with the undersigned officer within (hours or days) from service of this notice.

The nuisance consists of: (describe the nuisance) and shall be abated by: (state action necessary to abate the particular nuisance).

In the event you fail to abate or cause to be abated the above nuisance as directed, the City will take such steps as are necessary to abate or cause to be abated the nuisance and the costs will be assessed against you as provided by law.

Date of Notice: _____

City of _____, Iowa

By: _____
(designate officer initiating notice)

NOTICE

REQUIRED SEWER CONNECTION

TO: _____
(Name)

(Street Address)
_____, Iowa

You are hereby notified that connection to the public sanitary sewer system is required at the following described property within _____ (____) days from service of this notice or that you must file written request for a hearing before the Council with the undersigned office within said time limit.

Description of Property

The nearest public sewer line within _____ (____) feet of the above described property is located

In the event you fail to make connection as directed, or file written request for hearing within the time prescribed herein, the connection shall be made by the City and the costs thereof assessed against you as by law provided.

Date of Notice: _____

City of _____, Iowa

By: _____, _____
(Name) (Title)

NOTICE OF HEARING

REQUIRED SEWER CONNECTION

TO: _____
(Name)

(Street Address)
_____, Iowa

You are hereby notified that the City Council of _____, Iowa, will meet on the ___ day of _____, 20___, at _____m. in the Council Chambers of the City Hall for the purpose of considering whether or not connection to the public sanitary sewer system shall be required at the following described property:

Description of Property

You are further notified that at such time and place you may appear and show cause why said connection should not be required.

You are further notified to govern yourselves accordingly.

Date of Notice: _____

City of _____, Iowa

By: _____, _____
(Name) (Title)

RESOLUTION AND ORDER

REQUIRED SEWER CONNECTION

BE IT RESOLVED, by the City Council of the City of _____, Iowa:

WHEREAS, notice has heretofore been served on the ____ day of _____, 20____, on _____, (Name of Property

Owner)

through _____, Agent, (Agent's Name or "None")

to make connection of the property described as

to the public sanitary sewer located _____ within _____ (_____) days from service of notice upon said owner or agent. and

(EITHER)

WHEREAS, a hearing was requested by the said owner or agent and the same was held at this meeting and evidence produced and considered by the City Council.

(OR AS ALTERNATE TO THE PRECEDING PARAGRAPH)

WHEREAS, the said owner or agent named above has failed to make such required connection within the time set, and after evidence was duly produced and considered at this meeting, and said owner or agent has failed to file a written request for hearing after being properly served by a notice to make such connection or request a hearing thereon.

NOW, THEREFORE, BE IT RESOLVED that the owner of said property, or said owner's agent, _____

(Name of Owner or Agent)

is hereby directed and ordered to make such required connection within _____ days after the service of this ORDER upon said owner or agent. and

BE IT FURTHER RESOLVED that the City Clerk be and the same is hereby directed to serve a copy of this ORDER upon said property owner or agent named above. and

BE IT FURTHER RESOLVED, that in the event the owner, or agent,

_____,
(Name of Owner or Agent)

fails to make such connection within the time prescribed above, then and in that event the City will make such connection and the cost thereof will be assessed against the property or owner

(Owner's Name), as provided by law.

(Address)

Moved by _____ to adopt.

Seconded by _____.

AYES: _____, _____, _____,
_____, _____, _____.

NAYS: _____, _____, _____,
_____, _____, _____.

Resolution approved this ___ day of _____, 20__.

Mayor

ATTEST:

City Clerk